

MOTORSCHUTZBÜGEL

Engine protection bar | Barra de protección de motor | Pare-moteur | Paracilindri motore

Art.-Nr: 70201-002

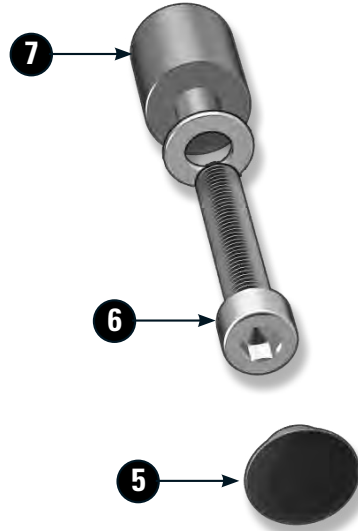
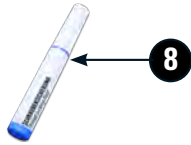

LEGENDE/Key/file Légende

- Anbau Tipp**
Fitting tip
Astuce de montage
- Achtung**
Attention
Attention
- Vergößerung**
Magnification
Grossissement
- Montagepaste**
Fitting lubricant
Lubrifiant de montage

- Schraube**
Screw
Vis
- Schraubensicherung**
Thread locking fluid
Freinfilets
- Drehmoment**
Torque
Torque
- Reiniger**
Cleaner
Nettoyant

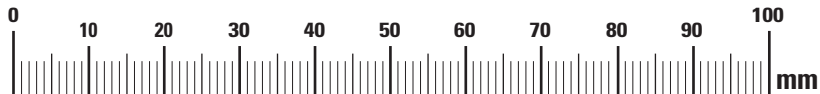

#	Bauteil component composant	DE Die Farben der Abbildungen dienen nur der Veranschaulichung. EN The colors are for illustrating purposes only. FR Les couleurs utilisées sont à titre indicatif seulement.	DIN	ISO	
1	Zylinderkopfschraube / Cylinder head screw	M10x70	912Z	4762Z	1
2	U-Scheibe / Washer	M10	125Z	7089	2
3	Distanzhülse / Sleeve	ØD 20 - Ød 11 - h 15mm			1
4	Motorschutzbügel / Protection bar				1
5	Abdeckkappe / Cap	Ø 25mm			1
6	Zylinderkopfschraube / Cylinder head screw	M10x60	912Z	4762Z	1
7	Distanzhülse / Sleeve	ØD 25 - Ød 11 - h 25mm			1
8	Schraubensicherung / Thread locking fluid				1

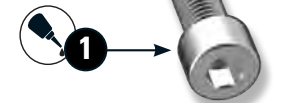
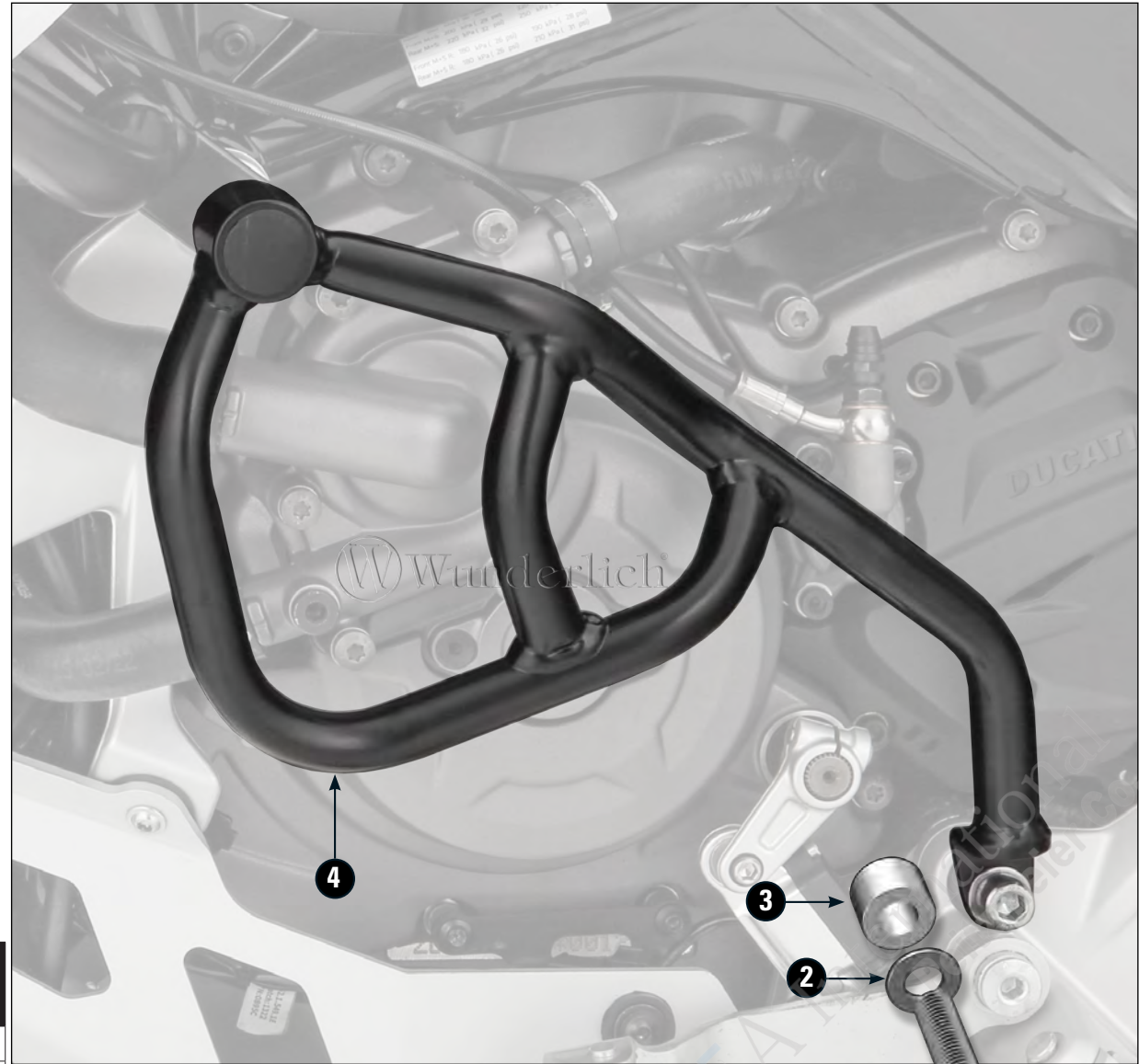



Orig. Schraube lösen und nach der Bügelmontage mit angegebenen Nm anziehen.
Loosen the original screw and tighten it to the specified Nm after mounting the protection bar.
Desserer la vis d'origine et la serrer au Nm spécifié après le montage de la barre de protection.

