

Choose language Sprache wählen



 Wunderlich®



Montageanleitung



Instrucciones de montaje



Monteringsanvisning



Assembly Instructions



Montagehandleiding

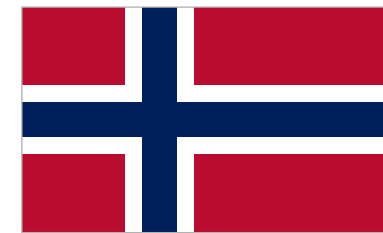

Monteringsanvisning

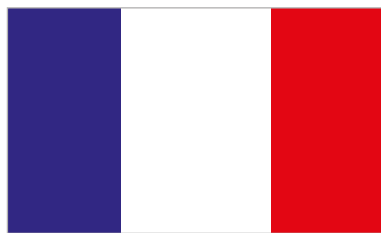

Notice de montage



Instrukcja montażu



Asennusohje



Istruzioni di montaggio

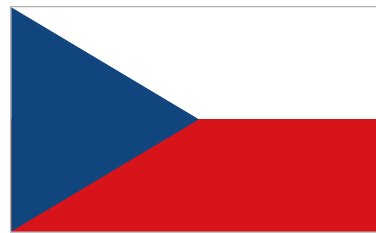

Montážní návod



Lieber Kunde, vielen Dank für Ihr Vertrauen und den Kauf dieses Wunderlich Produktes.

Diese Montageanleitung unterstützt Sie bei der sicheren und fachgerechten Installation Ihres Produkts.

Wichtiger Hinweis

Bitte lesen Sie diese Anleitung vollständig, bevor Sie mit der Montage beginnen.

Support

Sollten während der Montage Fragen auftreten, wenden Sie sich bitte vor Beginn der Arbeiten an unseren Support:

Tel.: +49 2641 3082-0

E-Mail: support@wunderlich.de

Wir wünschen Ihnen viel Freude mit Ihrem Wunderlich Produkt und allzeit gute Fahrt.

Ihr #TeamWunderlich



#31431-00x

Fußrastenverlegung

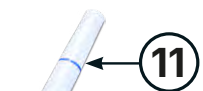

11



12

Legende

- Anbau Tipp
- Achtung
- Vergrößerung
- Montagepaste
- Schraube
- Schraubensicherung
- Drehmoment
- Reiniger

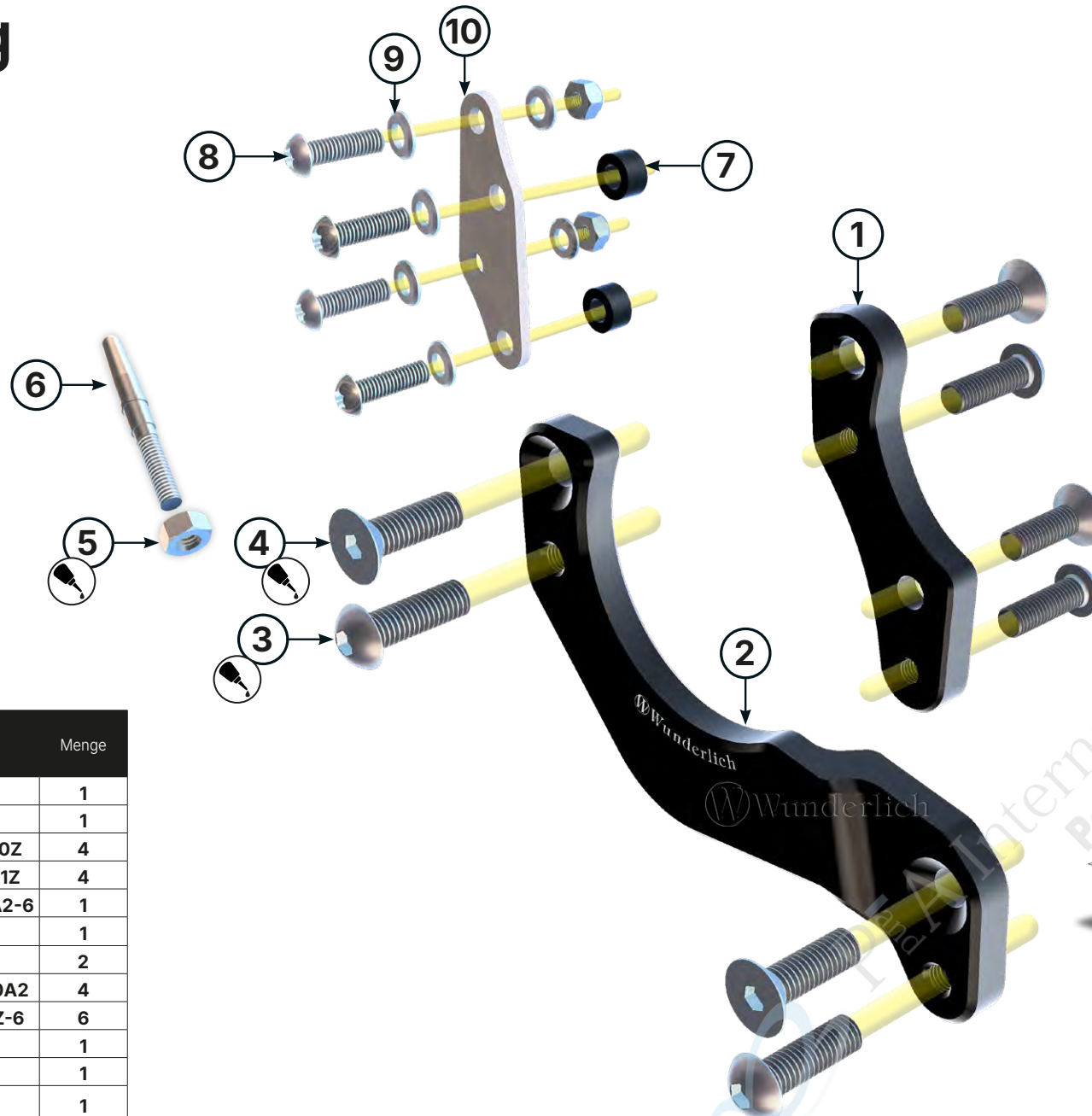

#	Bauteil	Menge
1	Rastenverlegung linke Seite	1
2	Rastenverlegung rechte Seite	1
3	Linsenkopfschraube M8×25	7380Z 4
4	Senkschraube M8×25	7991Z 4
5	Sechskantmutter M6	934A2-6 1
6	Druckbolzen	1
7	Hülse ØD 13,0 - Ød 7,0 - h 7,0 mm	2
8	Linsenkopfschraube M6×20	7380A2 4
9	Unterlegscheibe M6	125Z-6 6
10	Verlegeblech Bremspumpe	1
11	Schraubensicherung	1
12	Montageaste	1

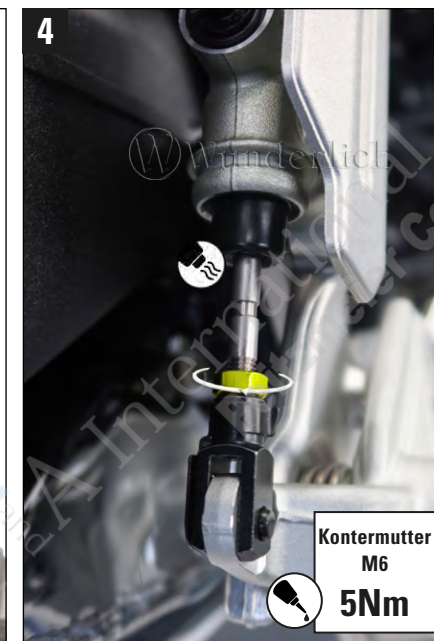
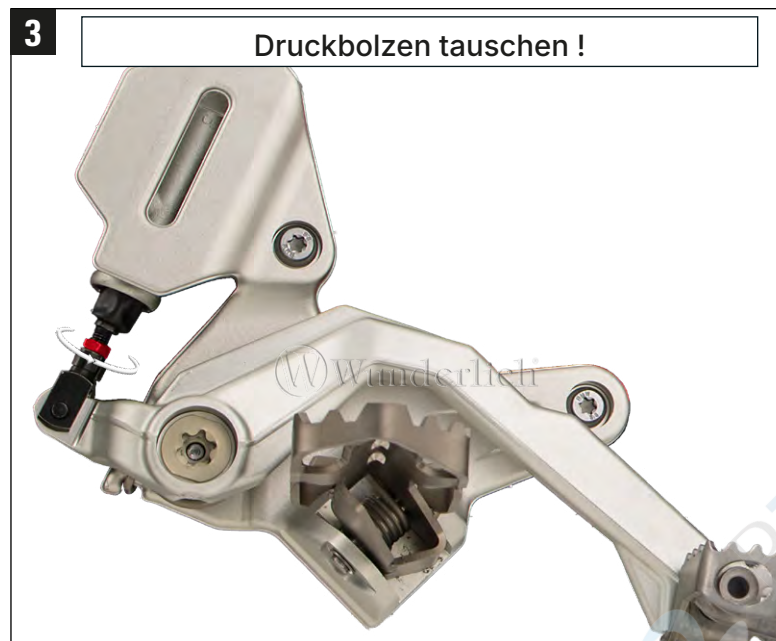
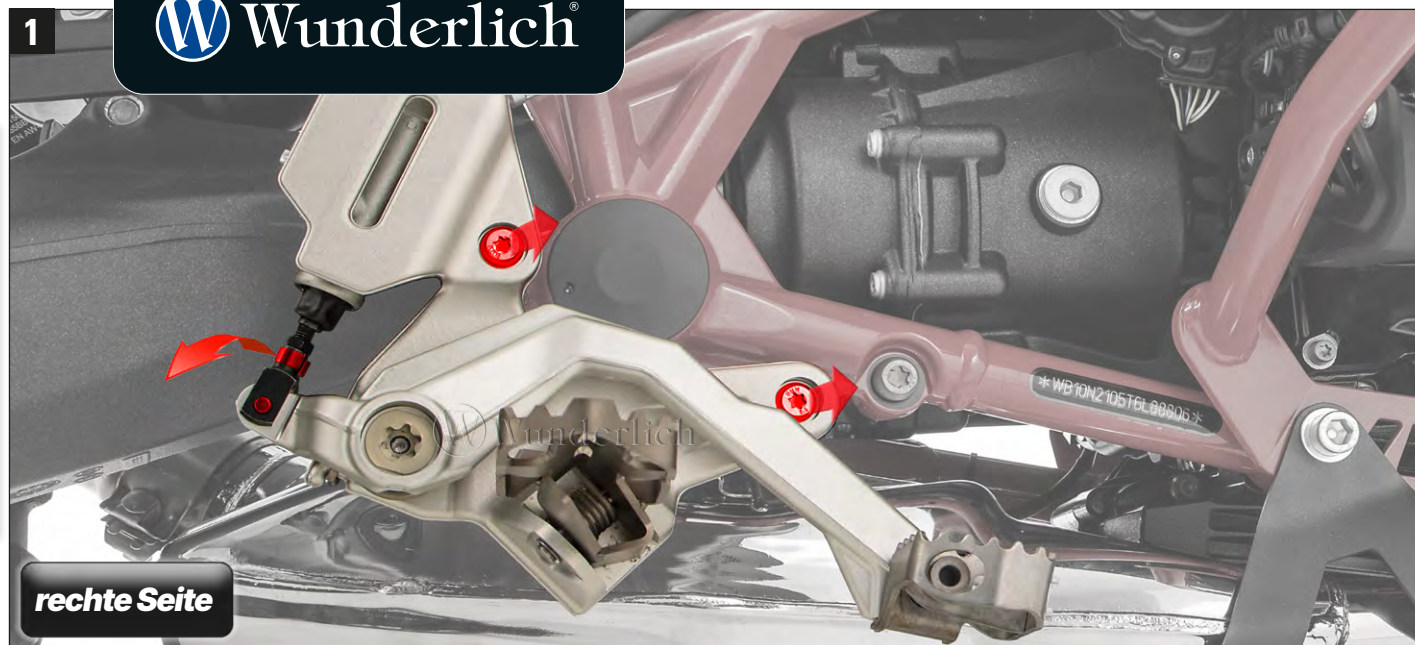

Die Montage darf nur von geschulten und sachkundigen Personen, oder in einer Fachwerkstatt durchgeführt werden.
 Nach der Montage das Hinterrad auf Freigängigkeit prüfen, gegebenenfalls Druckbolzen / Bremshebel einstellen (Schnüffelspiel / Spaltmaß 1,3 mm)

5



6

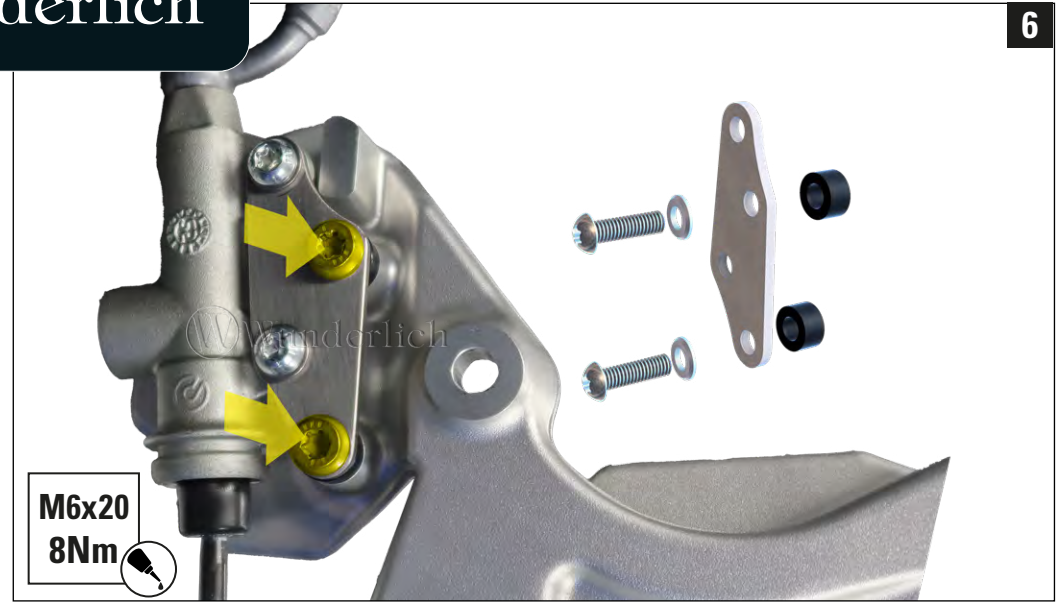

7

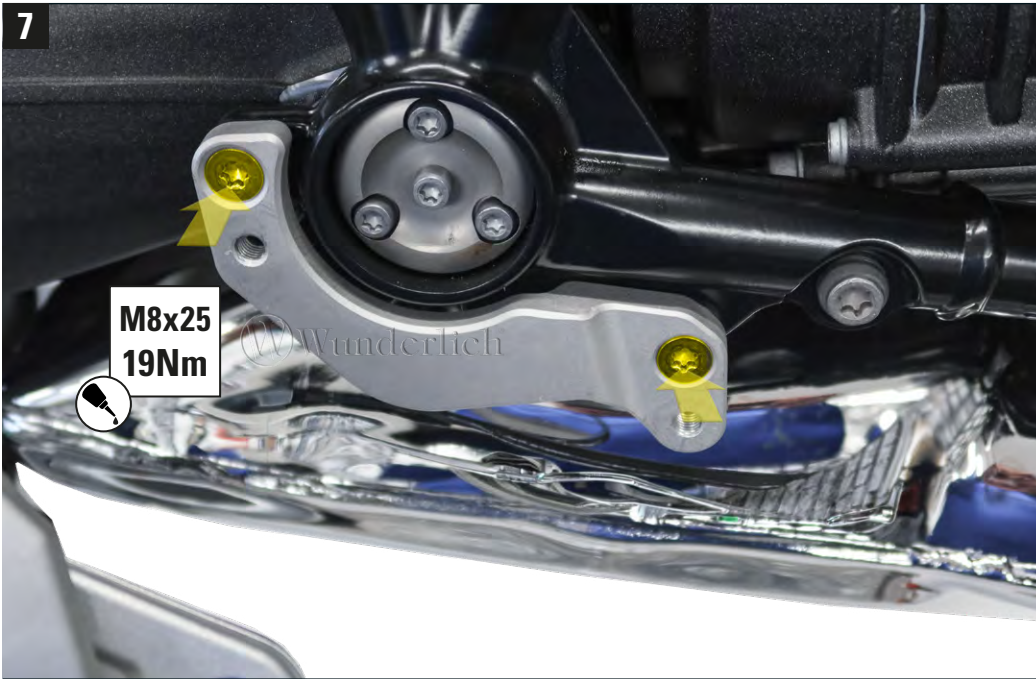

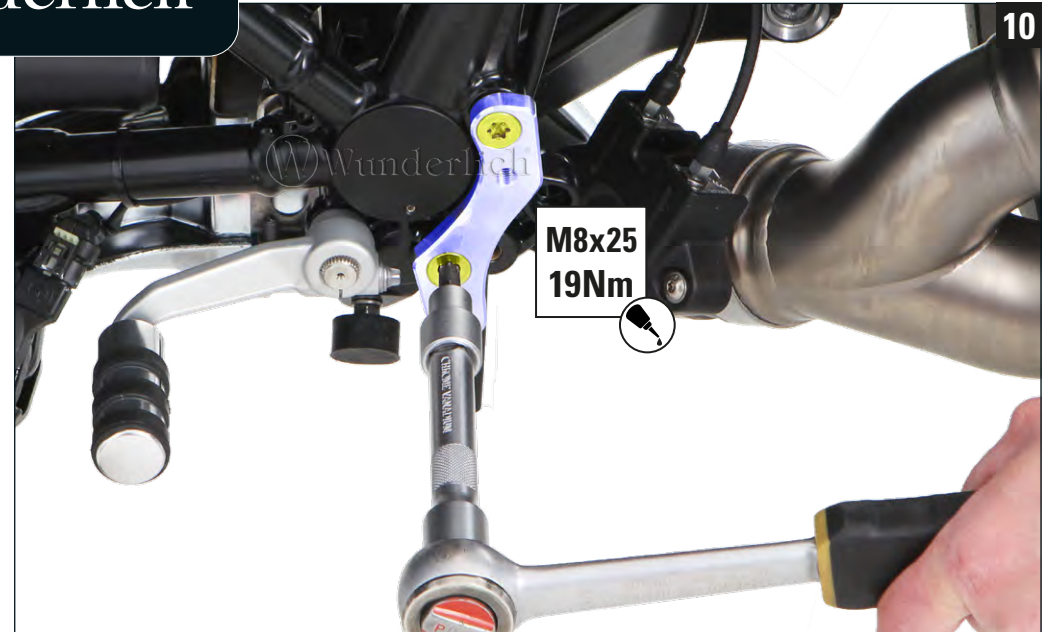

Schalthebel einstellen !



Dear Customer, thank you for your trust and for purchasing this Wunderlich product.



This installation guide will assist you in the safe and proper installation of your product.

Important Note

Please read this guide completely before starting the installation.

Support

If you have any questions during the installation, please contact our support before beginning the work:

Tel.: +49 2641-3082-240

E-Mail: support@wunderlich.de

We wish you much enjoyment with your Wunderlich product and always a safe ride.

Your #TeamWunderlich



#31431-00x



Footrest Relocation

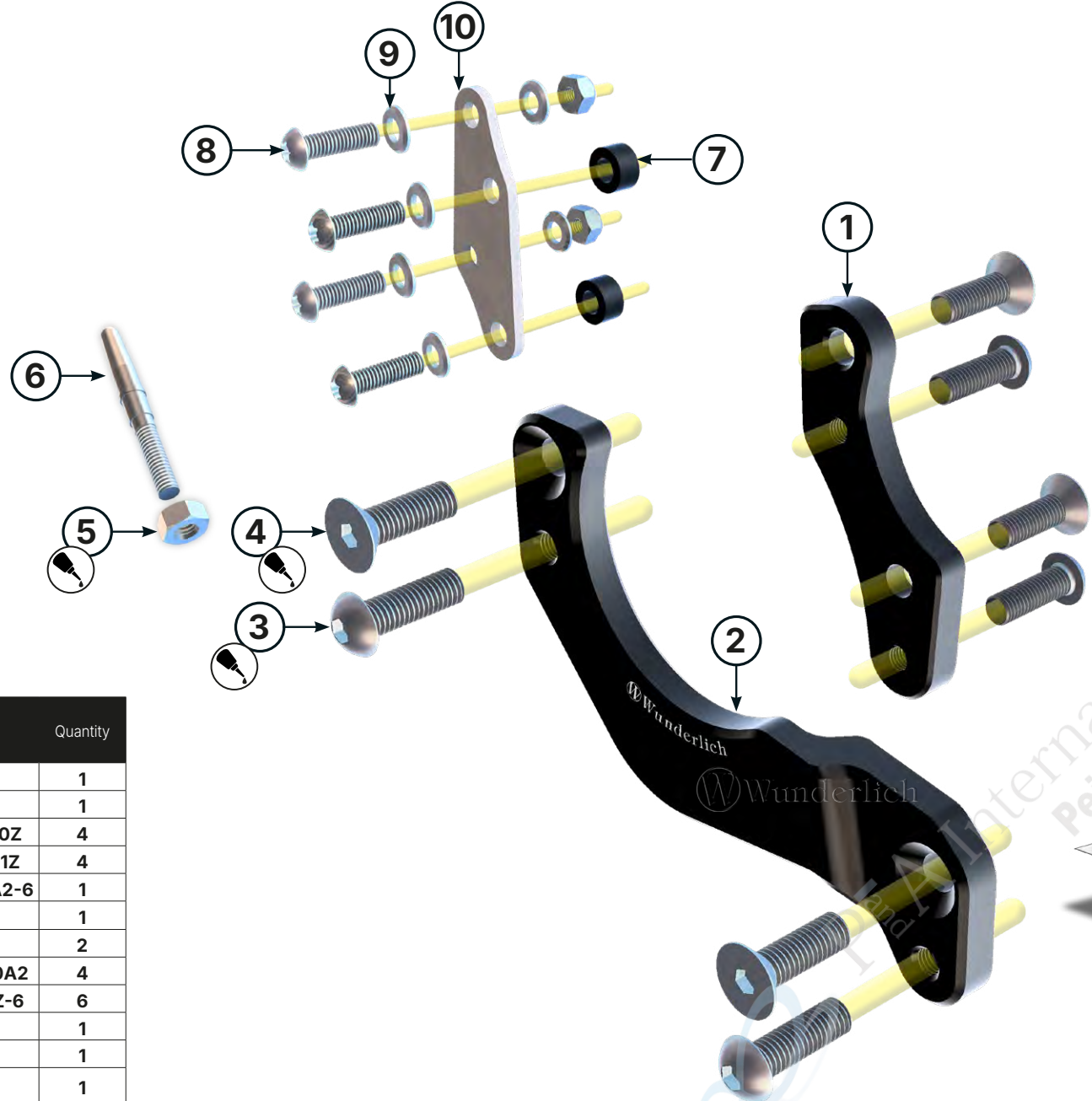
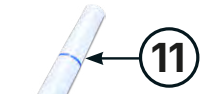

- Legend**
- Assembly Tip
 - Caution
 - Enlargement
 - Assembly Paste
 - Screw
 - Screw lock
 - Torque
 - Cleaner

#	Component	Quantity	
<small>The colours of the illustrations are for illustrative purposes only.</small>			
1	Footrest relocation left side		1
2	Footrest relocation right side		1
3	Pan head screw M8×25	7380Z	4
4	Countersunk screw M8×25	7991Z	4
5	Hex nut M6	934A2-6	1
6	Pressure bolt		1
7	Sleeve ØD 13.0 - Ød 7.0 - h 7.0 mm		2
8	Pan head screw M6×20	7380A2	4
9	Washer M6	125Z-6	6
10	Relocation plate brake pump		1
11	Screw lock		1
12	Assembly branch		1

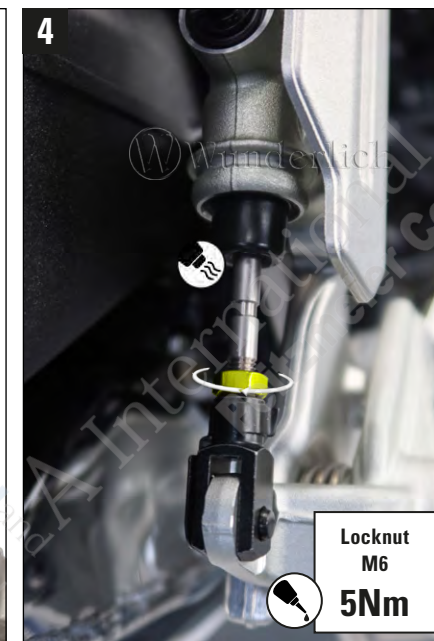
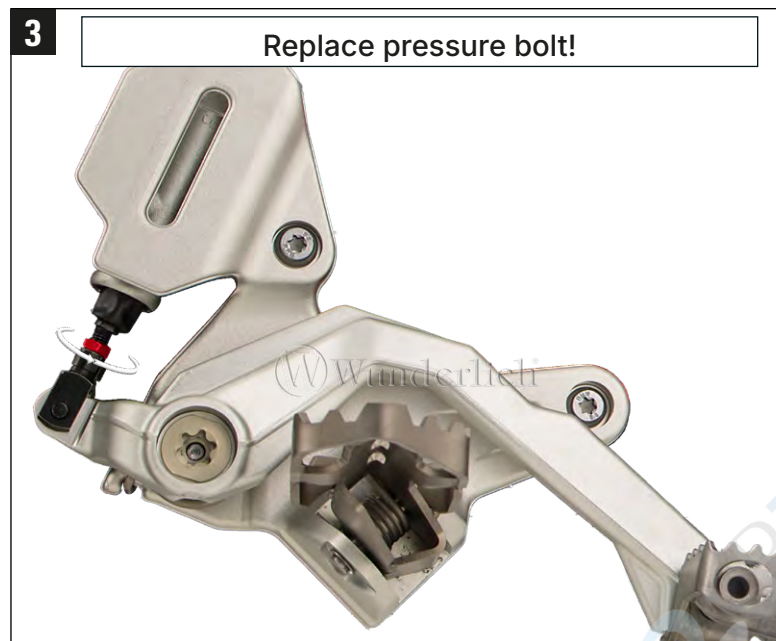

The assembly must only be carried out by trained and knowledgeable persons, or in a specialist workshop.
After assembly, check the rear wheel for clearance, adjust pressure bolt / brake lever if necessary (gap 1.3 mm)

5



6

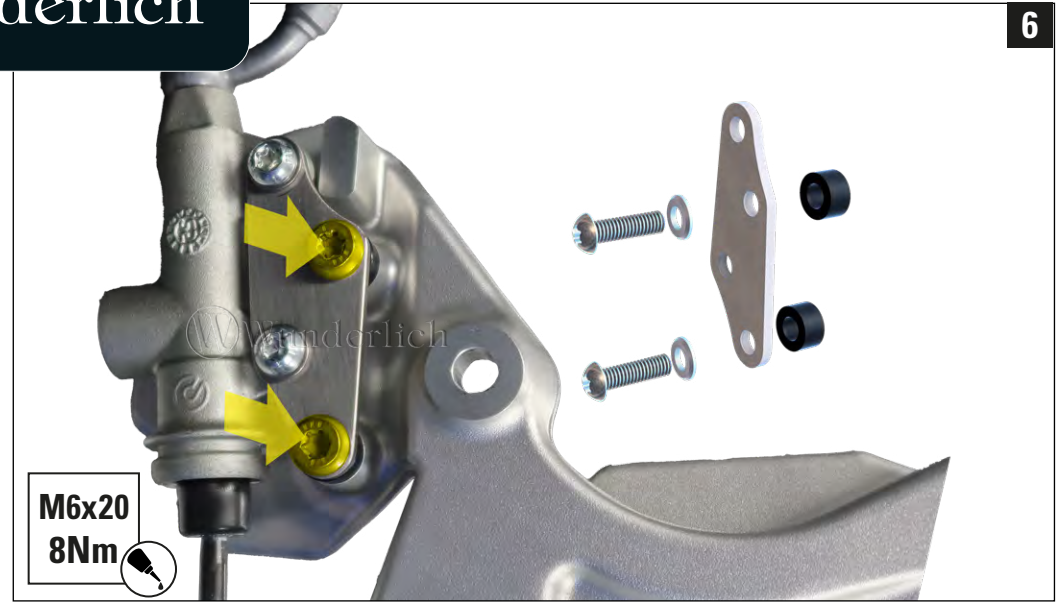

7

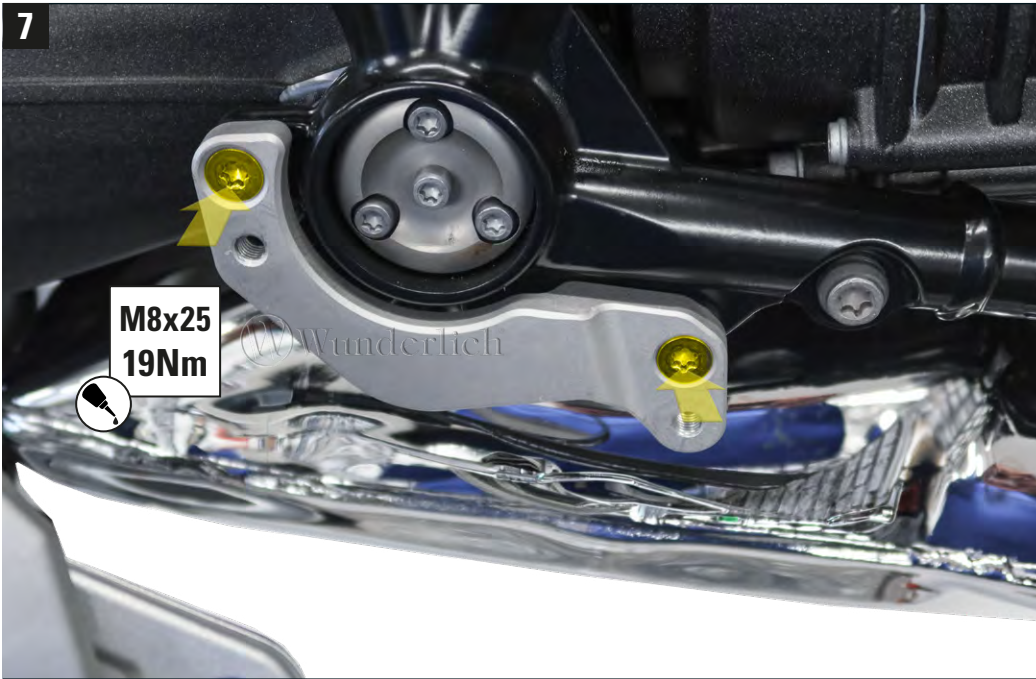

8

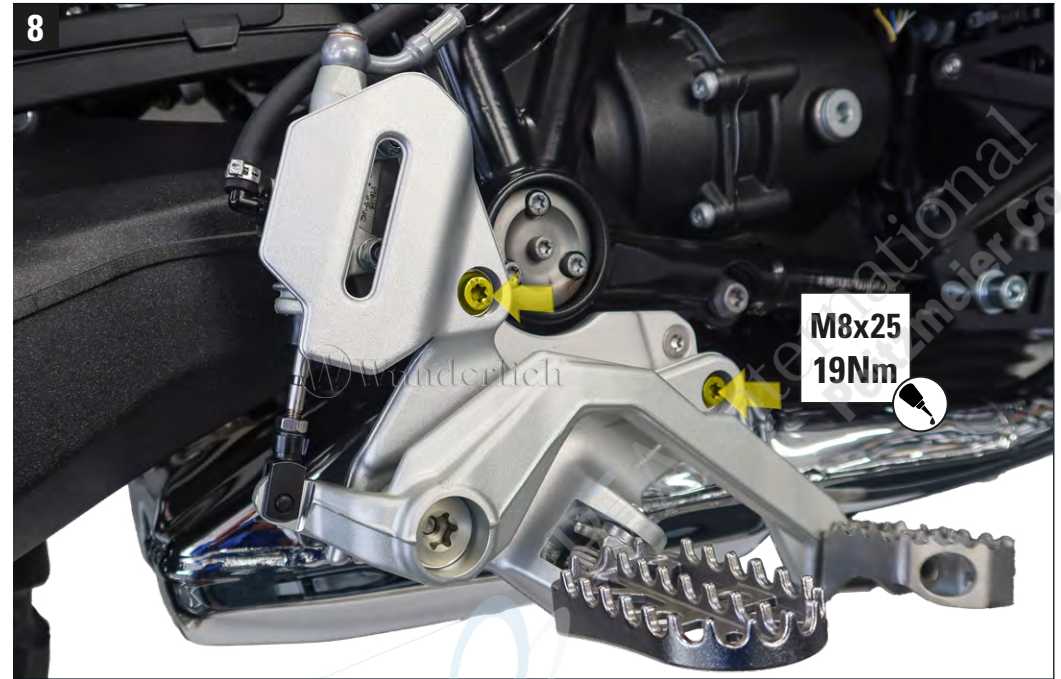

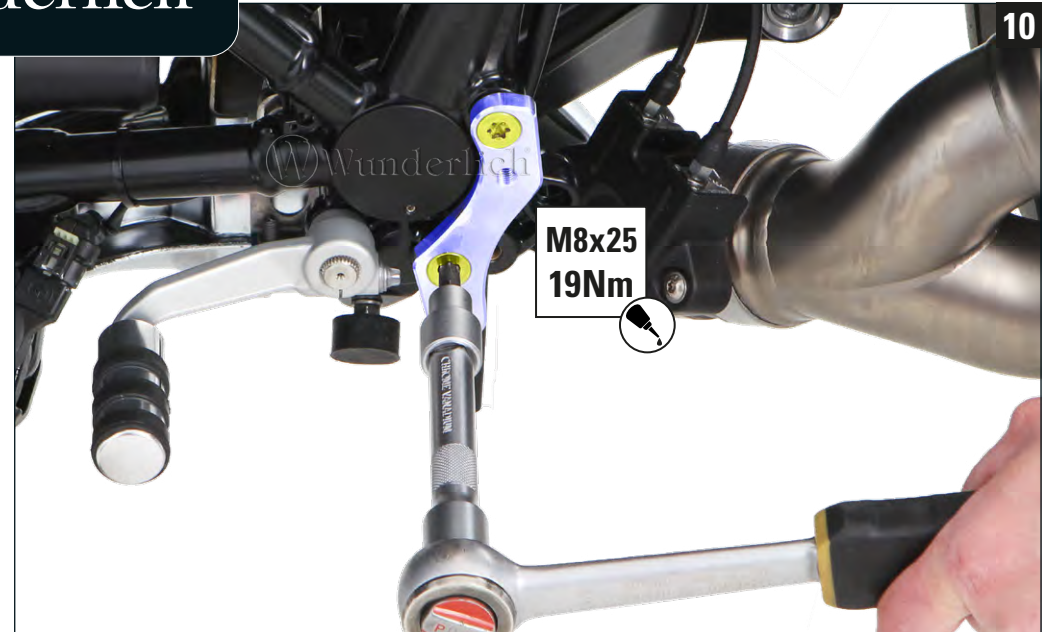

Adjust gear-shifter!



Cher client, merci pour votre confiance et l'achat de ce produit Wunderlich.

Ce manuel de montage vous aide à installer votre produit de manière sûre et professionnelle.

Remarque importante

Veillez lire entièrement ce manuel avant de commencer l'installation.

Support

Si vous avez des questions pendant l'installation, veuillez contacter notre support avant de commencer les travaux :

Tél. : +33 800 902350

E-mail : support@wunderlich.de

Nous vous souhaitons beaucoup de plaisir avec votre produit Wunderlich et un bon voyage en toute sécurité.

Votre #TeamWunderlich



#31431-00x

Déplacement des repose-pieds

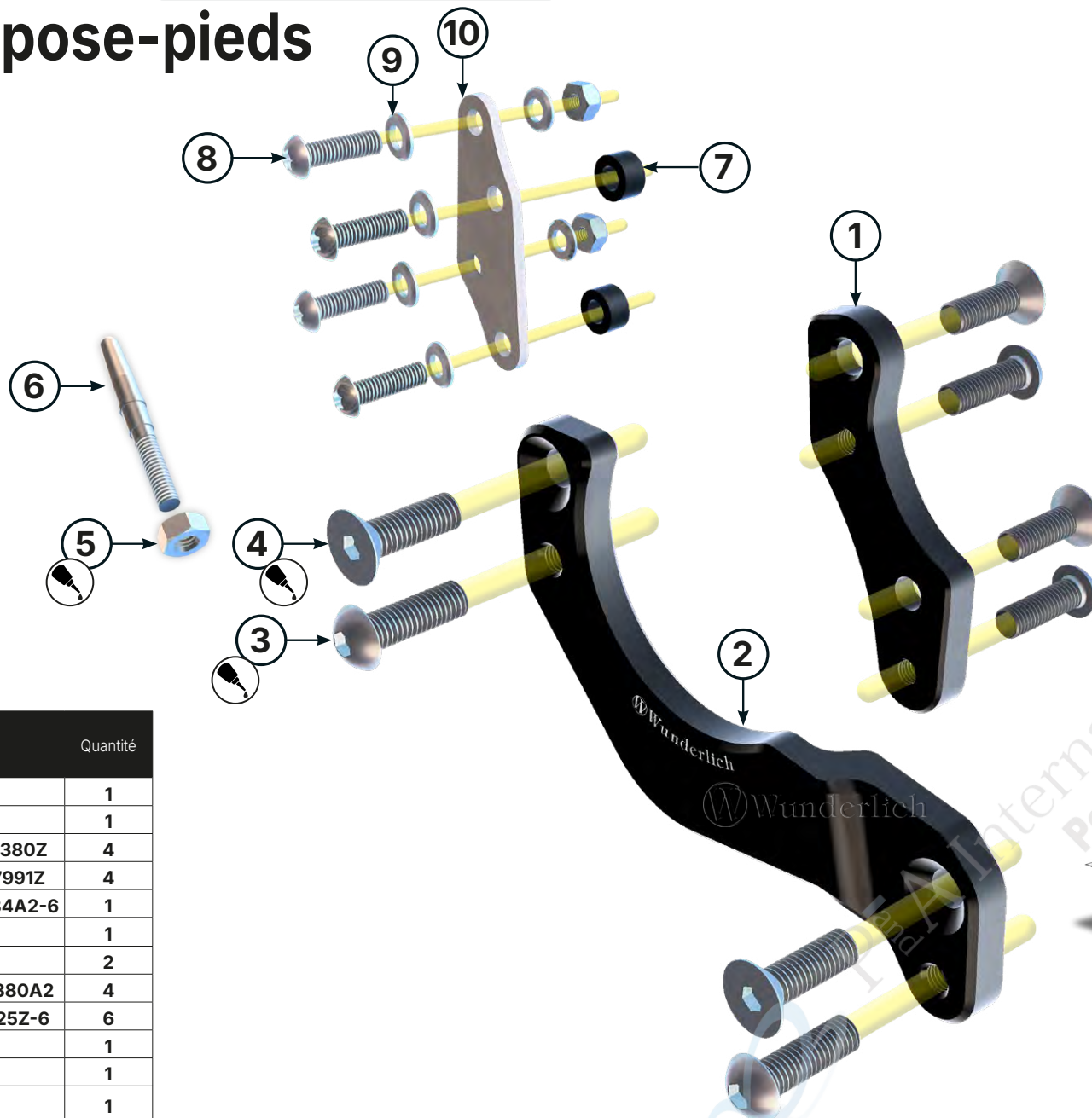
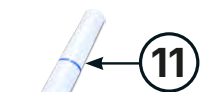

Légende



#	Composant	Quantité	
Les couleurs des illustrations servent uniquement à des fins d'illustration.			
1	Déplacement des repose-pieds côté gauche		1
2	Déplacement des repose-pieds côté droit		1
3	Vis à tête cylindrique M8×25	7380Z	4
4	Vis à tête fraisée M8×25	7991Z	4
5	Écrou hexagonal M6	934A2-6	1
6	Poussoir		1
7	Douille ØD 13,0 - Ød 7,0 - h 7,0 mm		2
8	Vis à tête cylindrique M6×20	7380A2	4
9	Rondelle M6	125Z-6	6
10	Plaque de déplacement pompe de frein		1
11	Frein filet		1
12	Pâte de montage		1

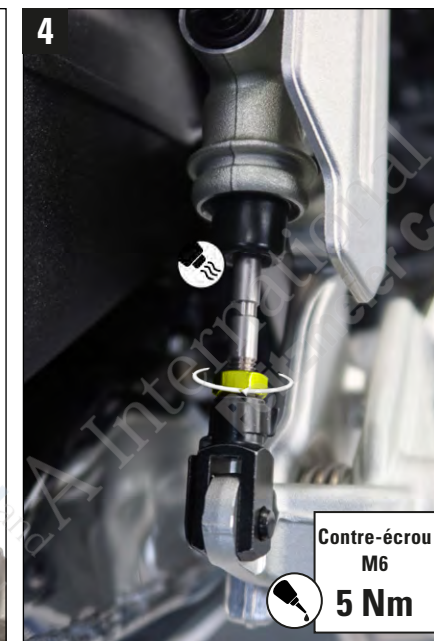
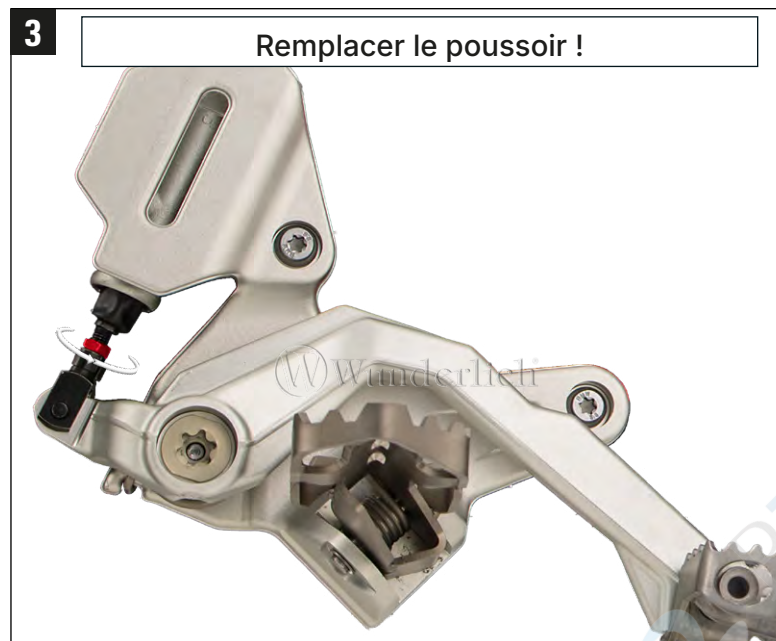
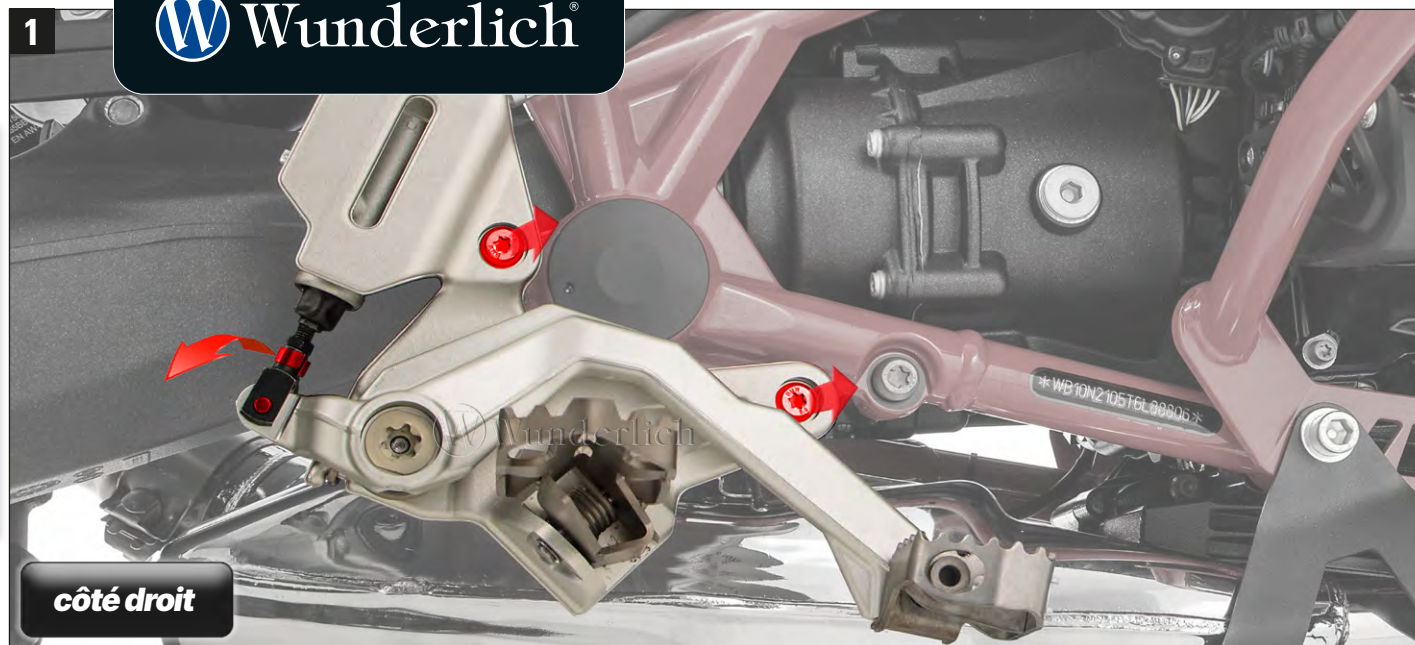

Le montage doit être effectué uniquement par des personnes formées et compétentes, ou dans un atelier spécialisé.
Après le montage, vérifier la liberté de mouvement de la roue arrière, ajuster si nécessaire le poussoir / levier de frein (jeu 1,3 mm)

5



6

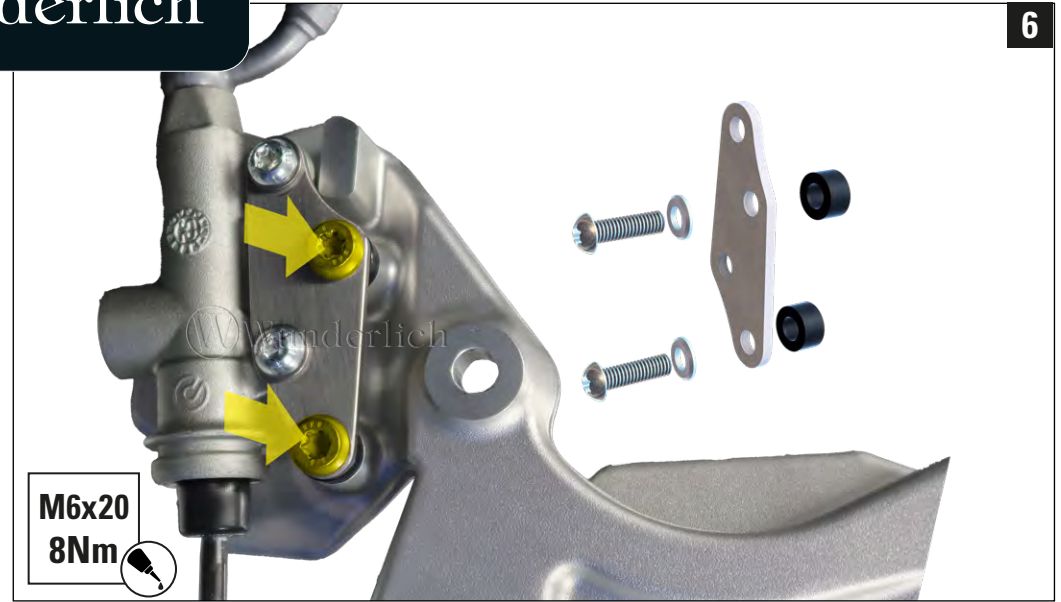

7

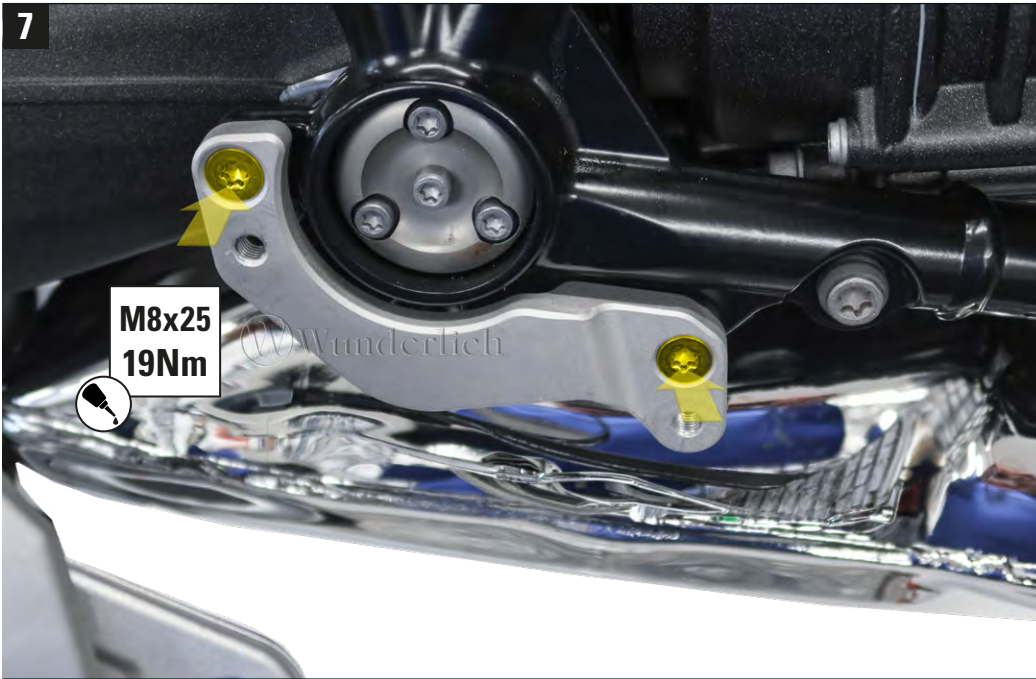

8

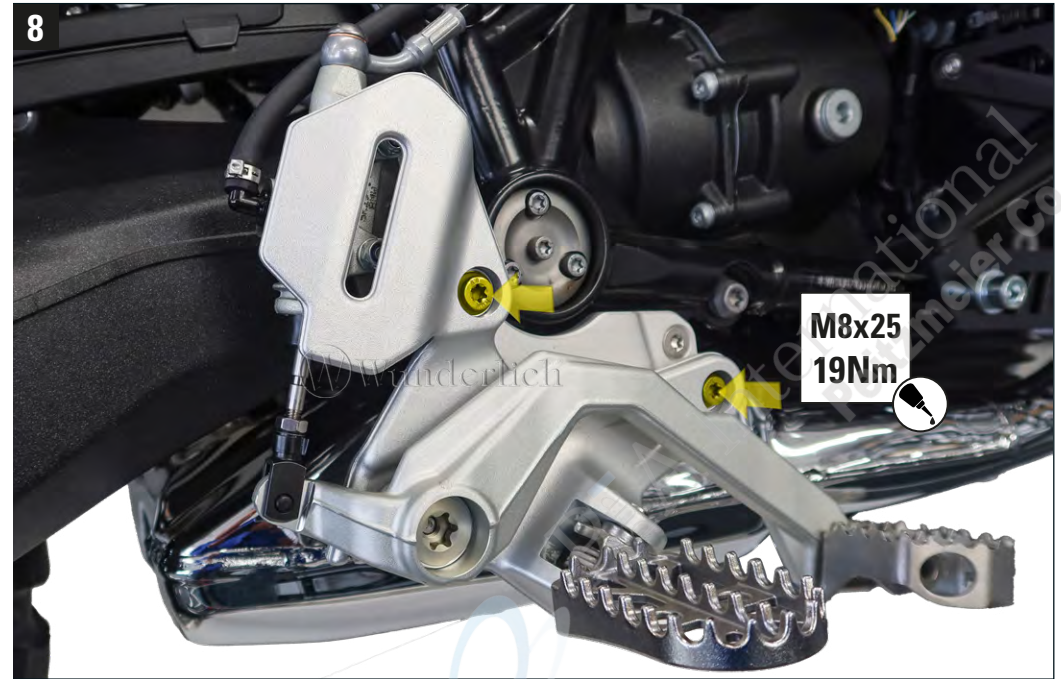



Régler le sélecteur !



Caro cliente, grazie per la fiducia e l'acquisto di questo prodotto Wunderlich.

Questo manuale di montaggio vi aiuterà nell'installazione sicura e corretta del vostro prodotto.

Avviso importante

Si prega di leggere completamente questo manuale prima di iniziare il montaggio.

Supporto

Se durante il montaggio dovessero sorgere domande, si prega di contattare il nostro supporto prima di iniziare i lavori:

Tel.: +39 800 975396

E-Mail: support@wunderlich.de

Vi auguriamo tanto divertimento con il vostro prodotto Wunderlich e buon viaggio in ogni momento.

Il #TeamWunderlich



#31431-00x

Kit di abbassamento delle pedane

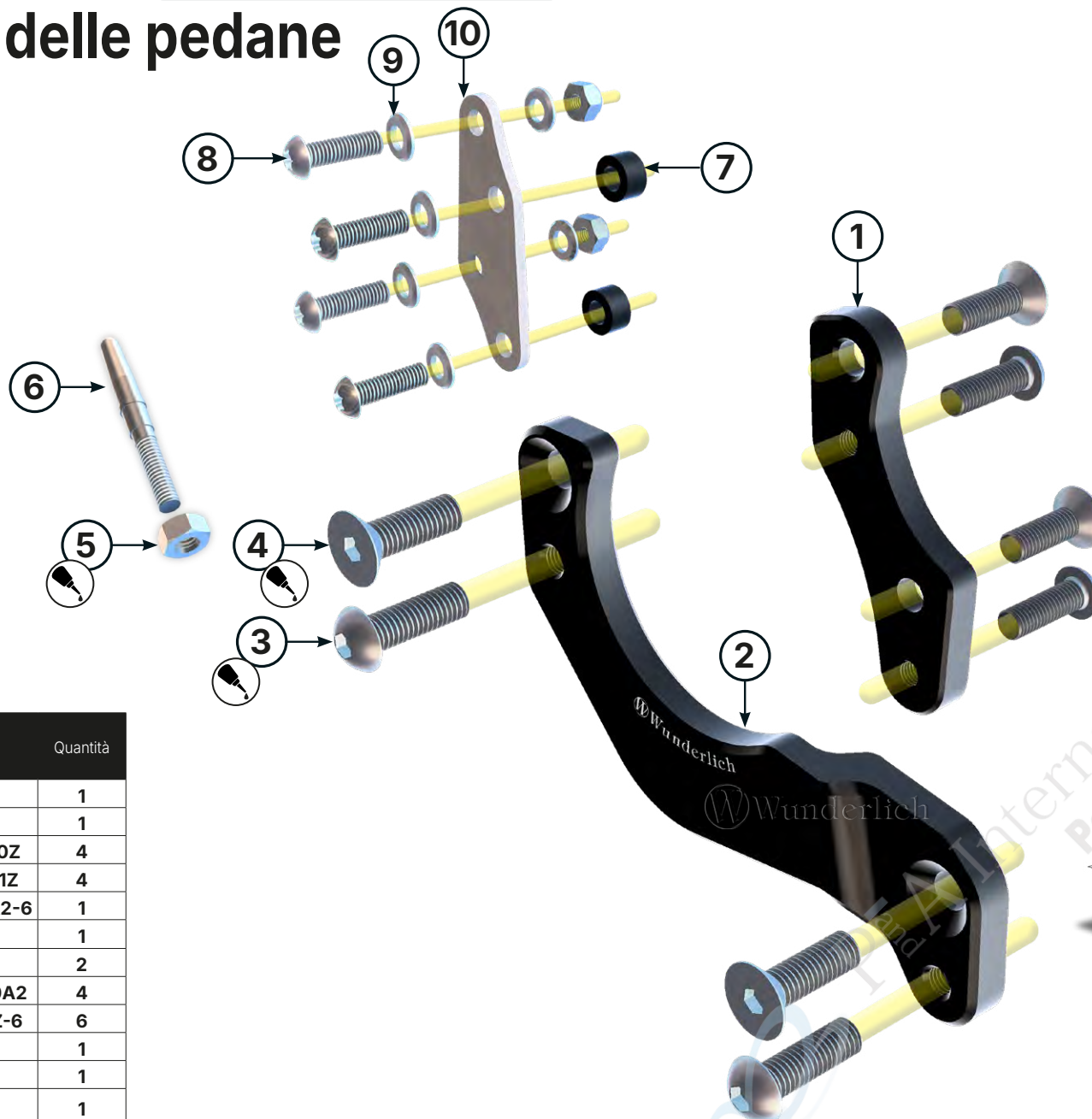
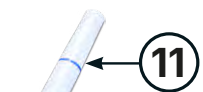

Legenda

- Suggerimento di montaggio
- Attenzione
- Ingrandimento
- Pasta di montaggio
- Vite
- Fissaggio vite
- Coppia
- Detergente

#	Componente	Quantità	
I colori delle illustrazioni servono solo a scopo illustrativo.			
1	Spostamento pedane lato sinistro		1
2	Spostamento pedane lato destro		1
3	Vite a testa cilindrica M8×25	7380Z	4
4	Vite a testa svasata M8×25	7991Z	4
5	Dado esagonale M6	934A2-6	1
6	Perno di pressione		1
7	Boccola ØD 13,0 - Ød 7,0 - h 7,0 mm		2
8	Vite a testa cilindrica M6×20	7380A2	4
9	Rondella M6	125Z-6	6
10	Piastra di spostamento pompa freno		1
11	Fissaggio vite		1
12	Asta di montaggio		1

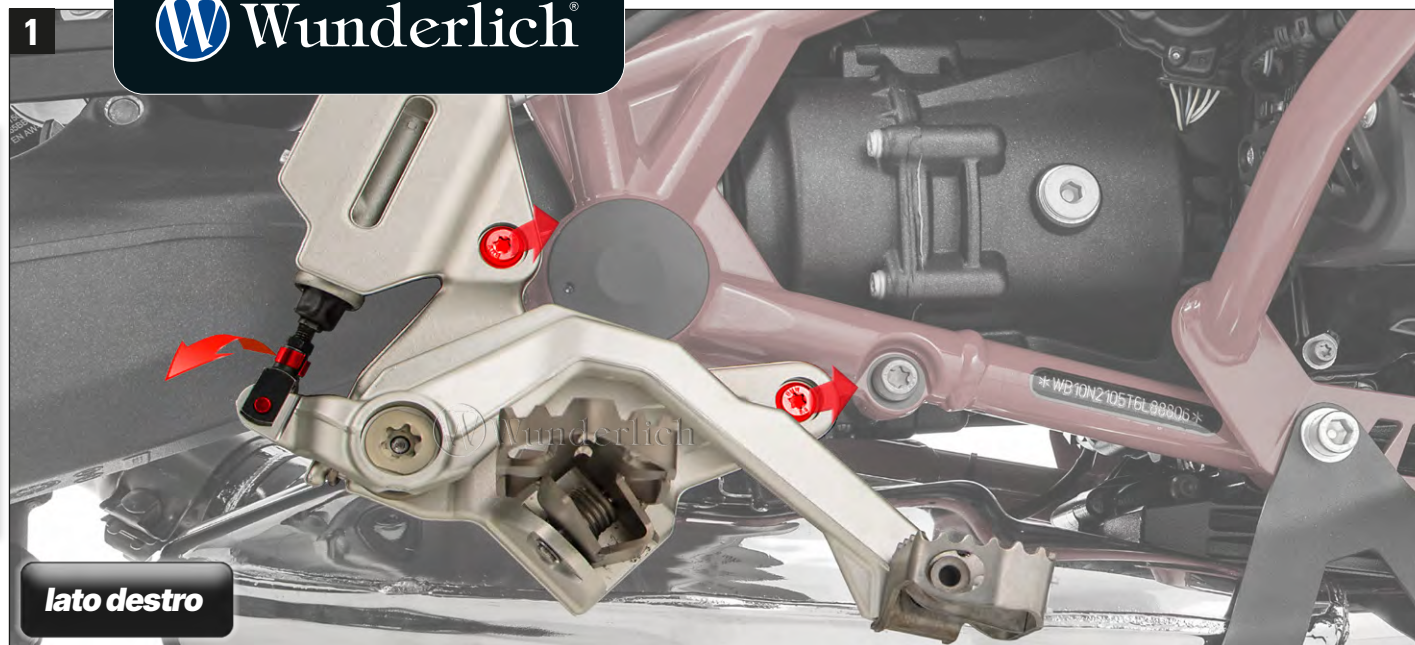

Il montaggio deve essere eseguito solo da personale qualificato e competente, o in un'officina specializzata.
 Dopo il montaggio, controllare la libertà di movimento della ruota posteriore, regolare se necessario il perno di pressione / leva freno (gioco 1,3 mm)

5



6

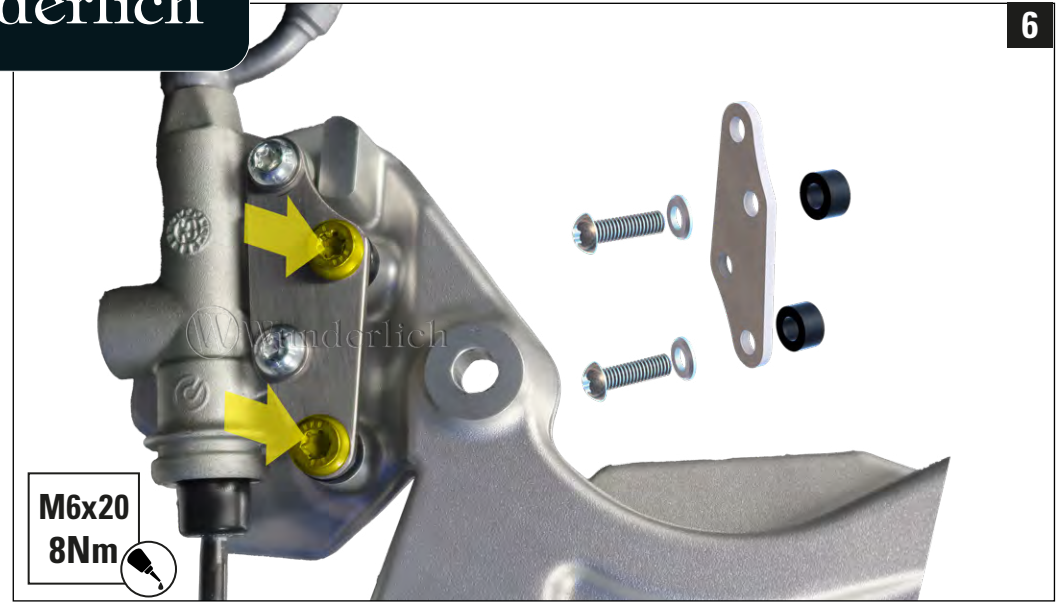

7

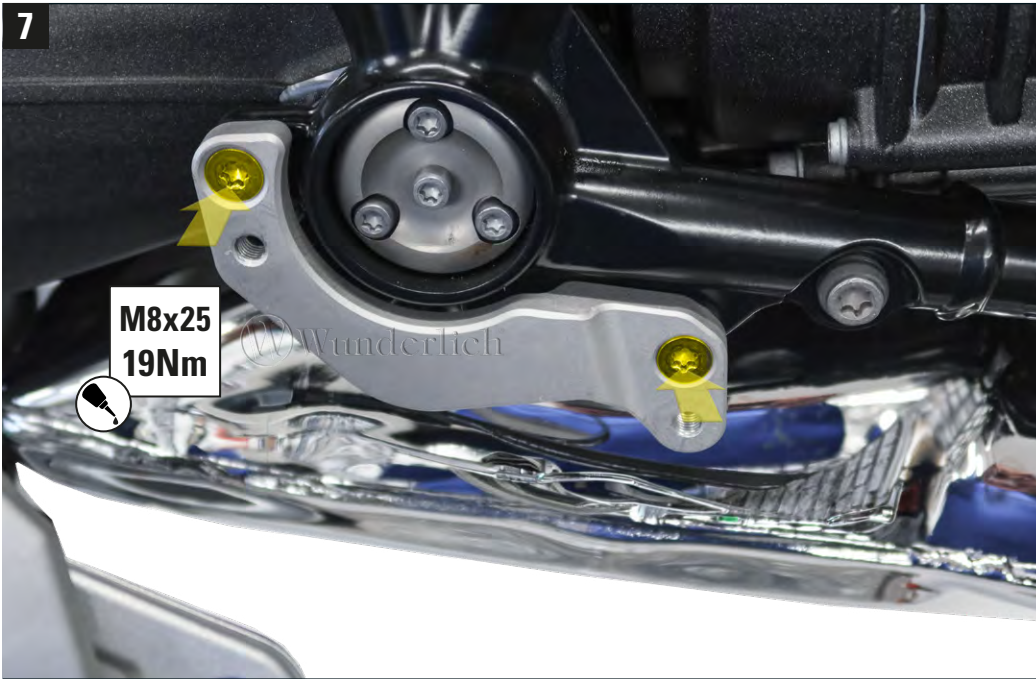

8

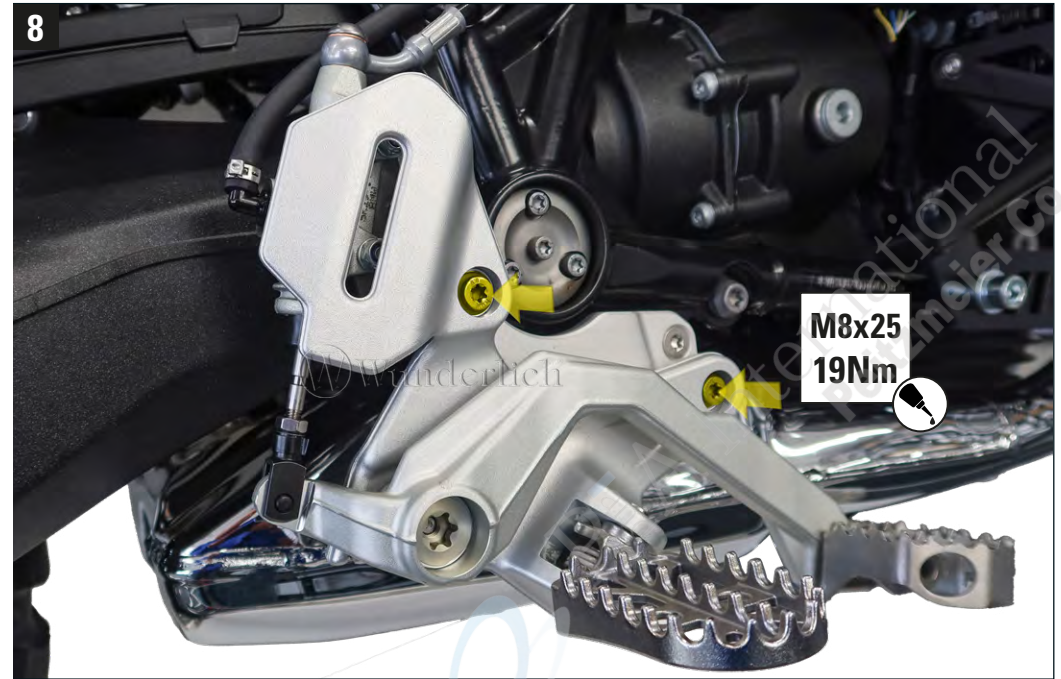

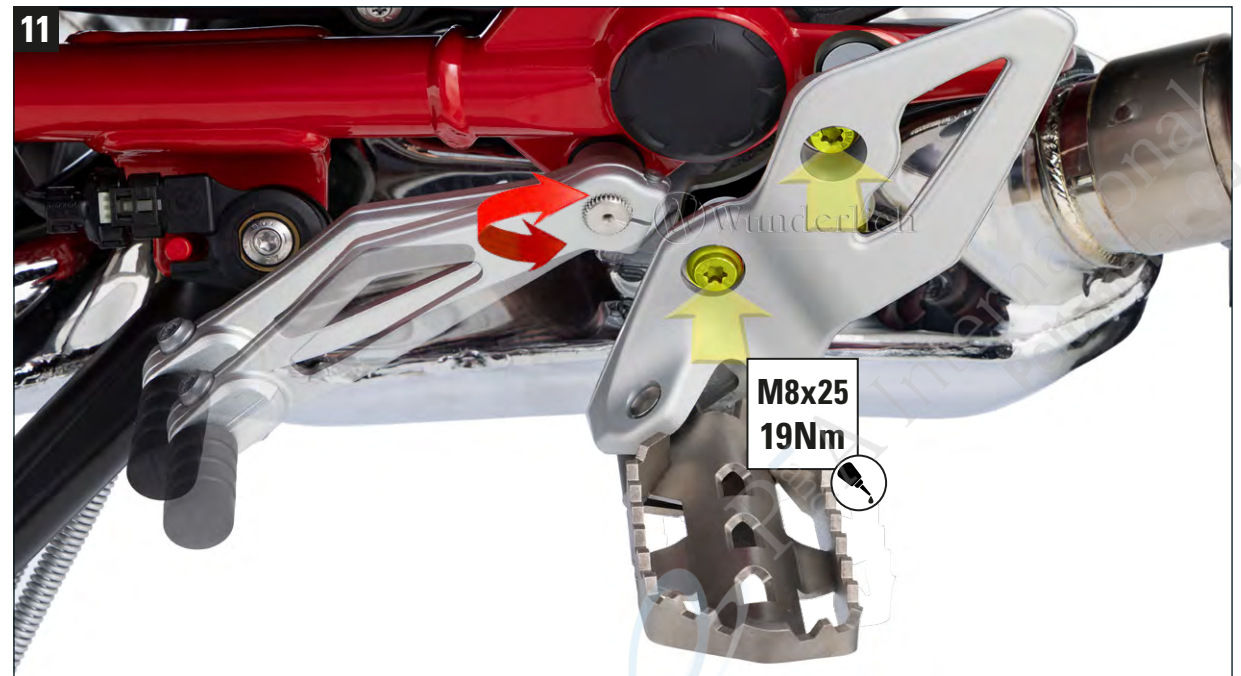
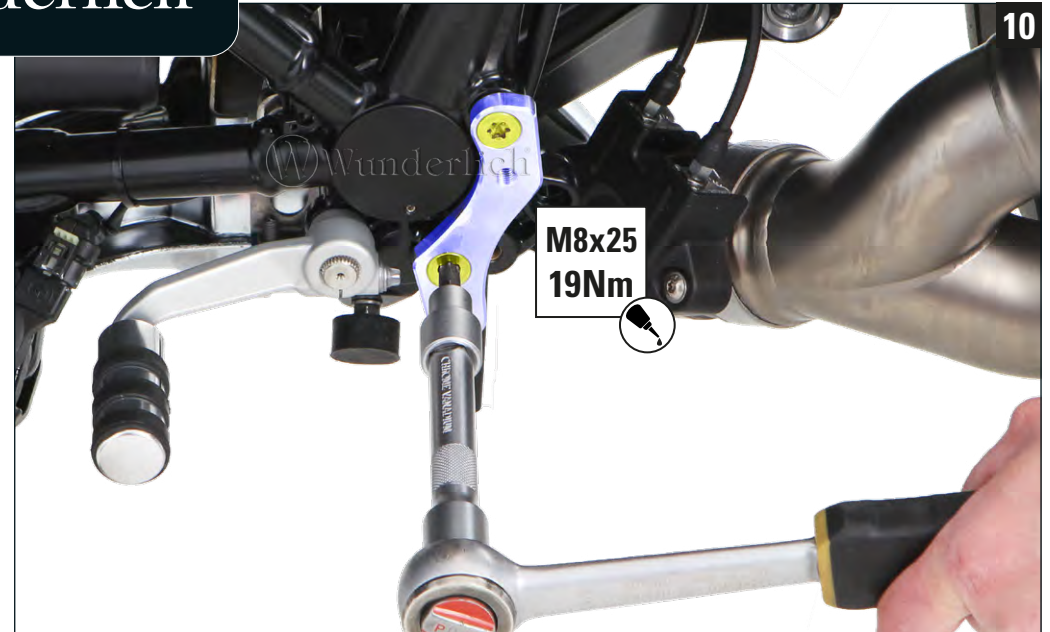

Regolare la leva del cambio!



Estimado cliente, muchas gracias por su confianza y la compra de este producto Wunderlich.

Este manual de montaje le ayudará en la instalación segura y adecuada de su producto.

Aviso importante

Por favor, lea este manual completamente antes de comenzar con el montaje.

Soporte

Si surgen preguntas durante el montaje, por favor contacte con nuestro soporte antes de comenzar:

Tel.: +34 900 802474

E-Mail: support@wunderlich.de

Le deseamos mucho disfrute con su producto Wunderlich y un buen viaje en todo momento.

Su #Teamwunderlich



#31431-00x

Desplazamiento de estribos lado izquierdo

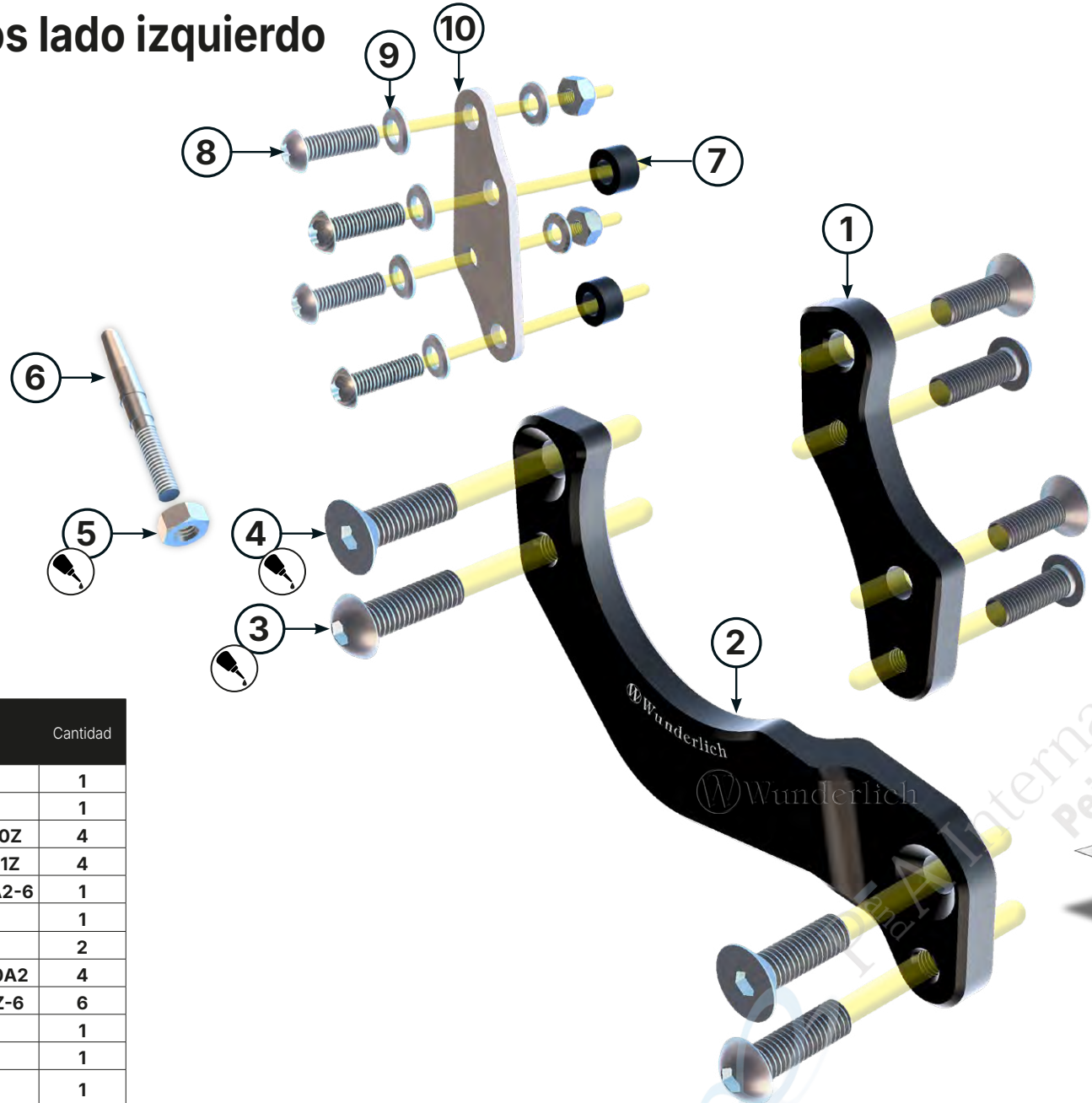
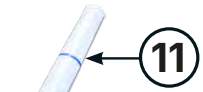

Leyenda



#	Componente	Cantidad	
Los colores de las ilustraciones son solo para fines de visualización.			
1	Desplazamiento de estribos lado izquierdo		1
2	Desplazamiento de estribos lado derecho		1
3	Tornillo de cabeza avellanada M8×25	7380Z	4
4	Tornillo avellanado M8×25	7991Z	4
5	Tuerca hexagonal M6	934A2-6	1
6	Perno de presión		1
7	Casquillo ØD 13,0 - Ød 7,0 - h 7,0 mm		2
8	Tornillo de cabeza avellanada M6×20	7380A2	4
9	Arandela M6	125Z-6	6
10	Placa de desplazamiento de la bomba de freno		1
11	Fijación de tornillos		1
12	Pasta de montaje		1

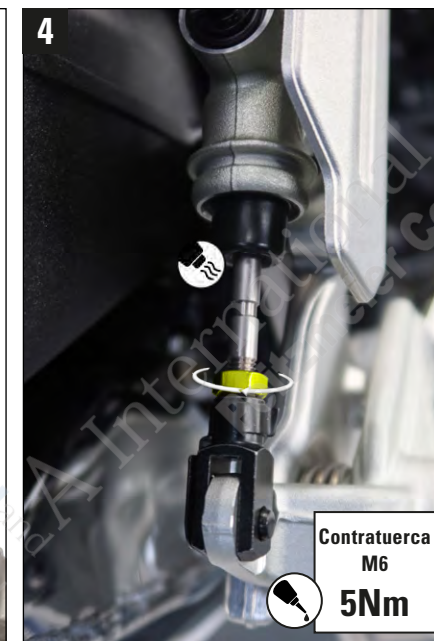
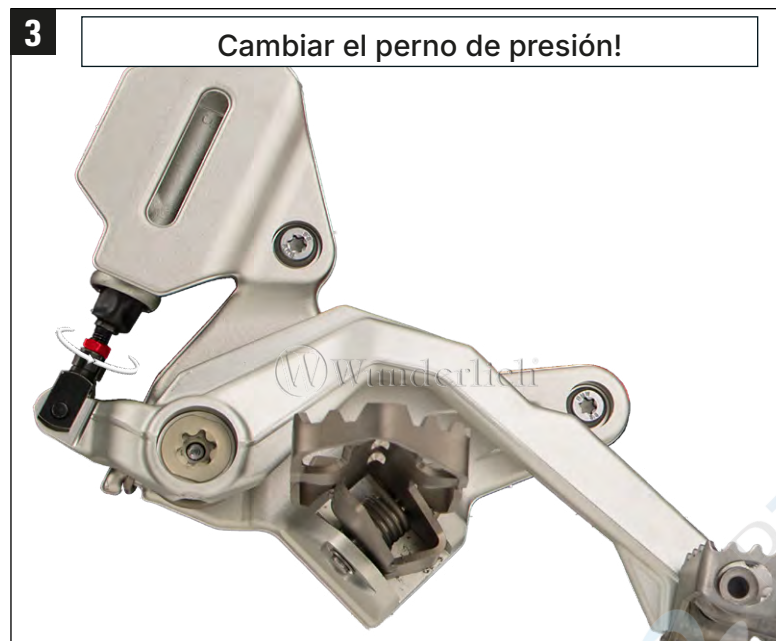
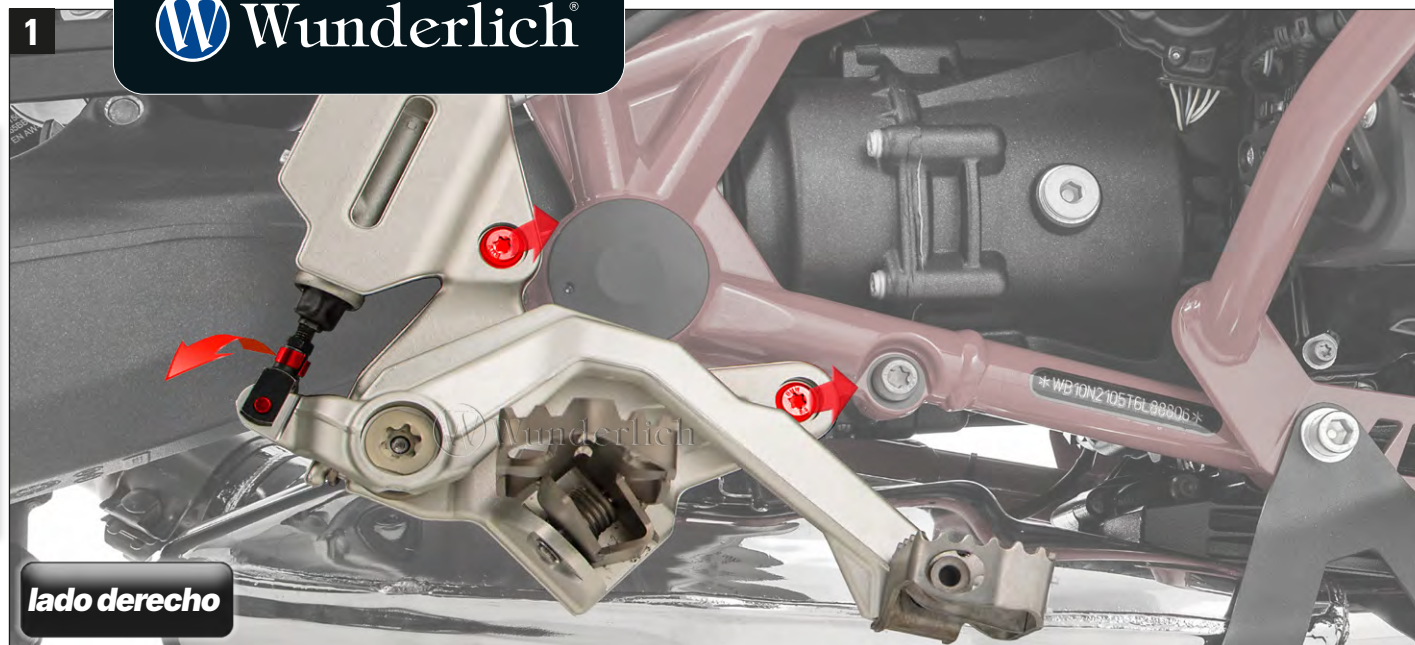

El montaje debe ser realizado solo por personas capacitadas y competentes, o en un taller especializado. Después del montaje, verificar la libertad de movimiento de la rueda trasera, ajustar el perno de presión / maneta de freno si es necesario (espacio de 1,3 mm)

5



6

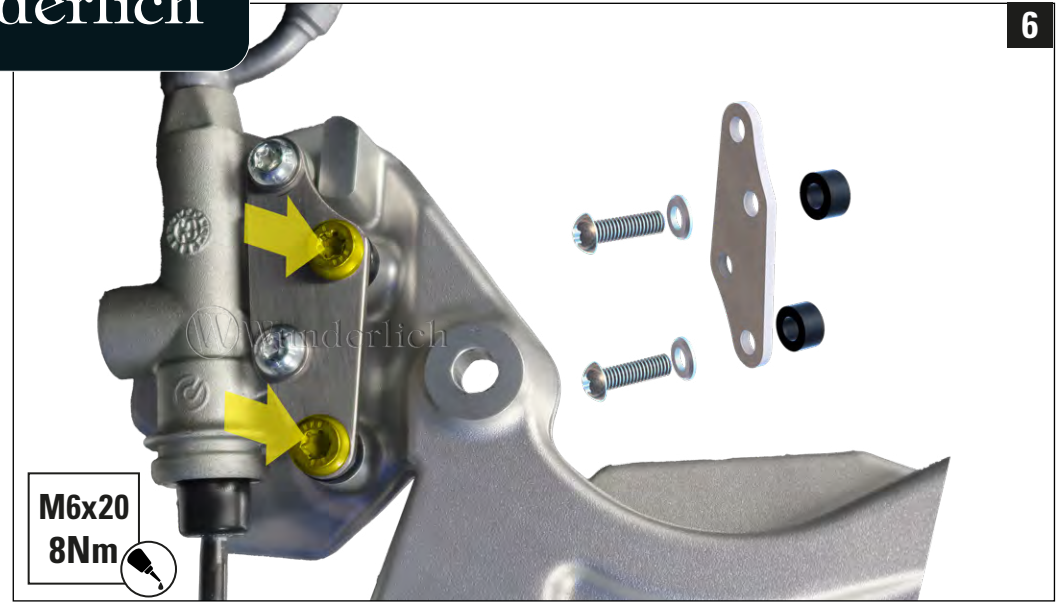

7

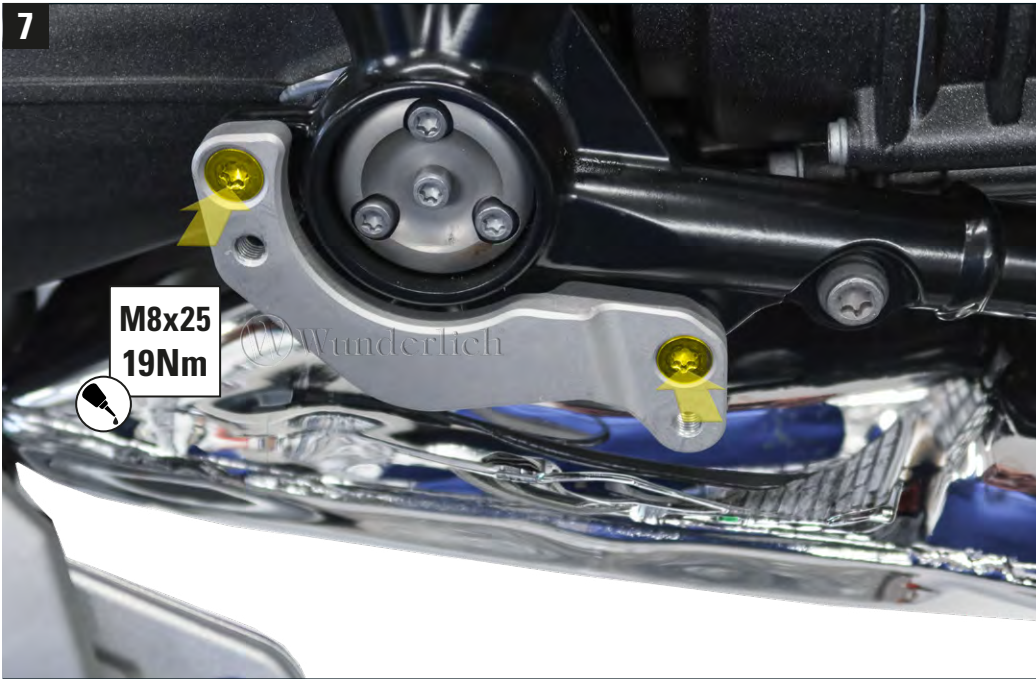

8

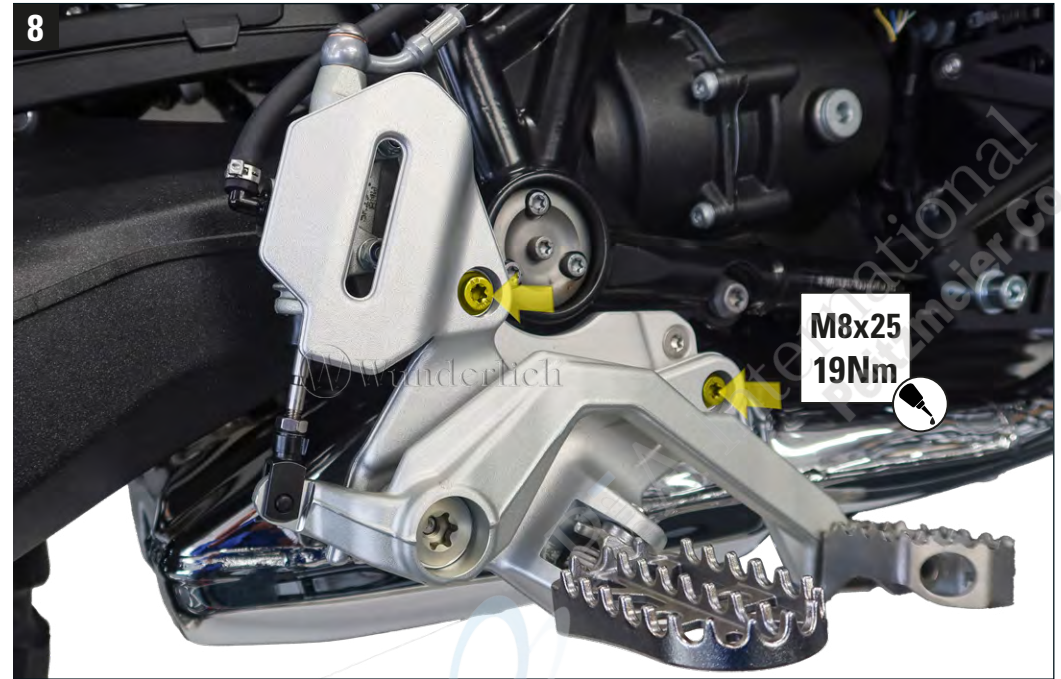

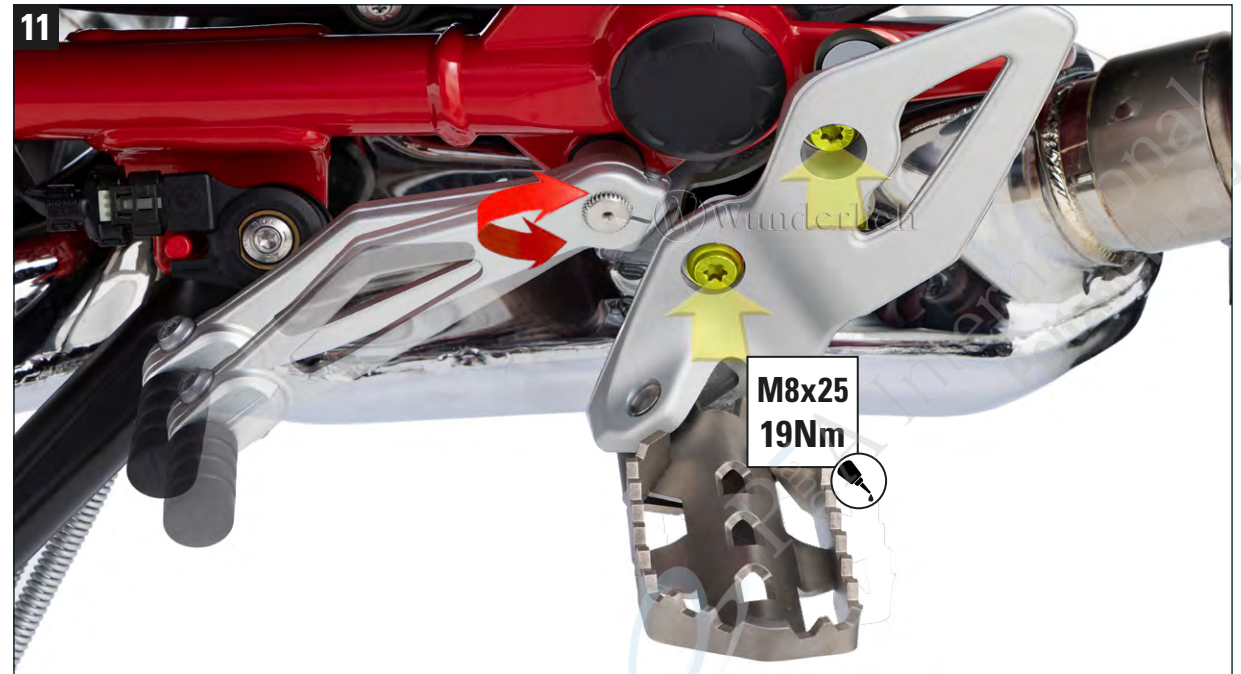

Ajustar la palanca de cambio!



Lieve klant, hartelijk dank voor uw vertrouwen en de aankoop van dit Wunderlich product.

Deze montagehandleiding ondersteunt u bij de veilige en vakkundige installatie van uw product.

Belangrijke opmerking

Lees deze handleiding volledig door voordat u met de montage begint.

Support

Mocht u tijdens de montage vragen hebben, neem dan voor aanvang van de werkzaamheden contact op met onze support:

Tel.: +49 2641-3082-240

E-mail: support@wunderlich.de

Wij wensen u veel plezier met uw Wunderlich product en altijd een goede reis.

Uw #TeamWunderlich



#31431-00x

Verplaatsing van voetsteunen

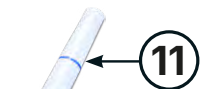

11



12

Legenda

- Montagetip
- Let op
- Vergroting
- Montagepasta
- Schroef
- Schroefborging
- Aanhaalmoment
- Reiniger

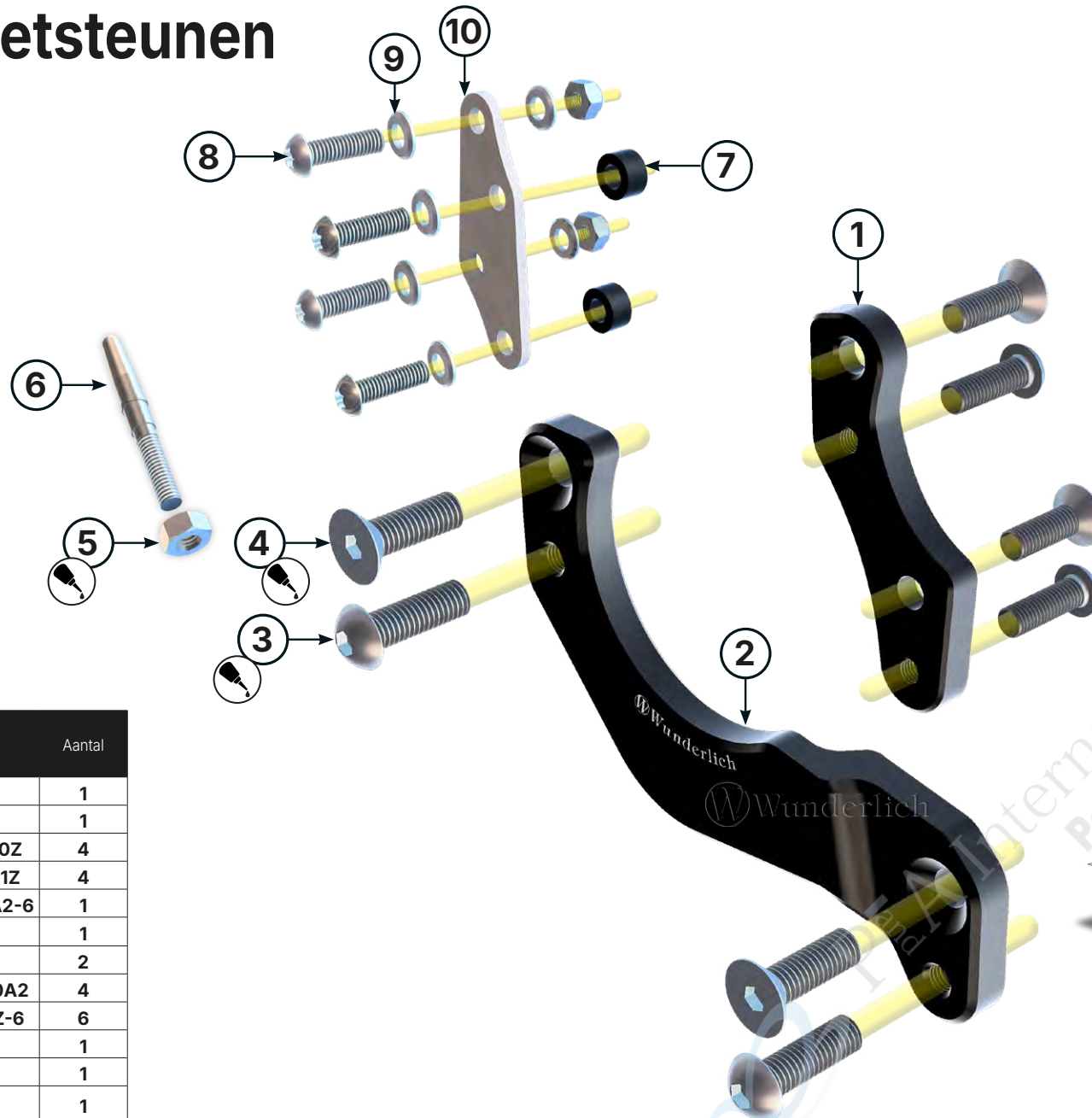

#	Onderdeel	Aantal
De kleuren van de afbeeldingen dienen alleen ter illustratie.		
1	Verplaatsing voetsteun linkerzijde	1
2	Verplaatsing voetsteun rechterzijde	1
3	Lenskopschroef M8×25	7380Z 4
4	Verzonken schroef M8×25	7991Z 4
5	Zeskantmoer M6	934A2-6 1
6	Drukpen	1
7	Huls ØD 13,0 - Ød 7,0 - h 7,0 mm	2
8	Lenskopschroef M6×20	7380A2 4
9	Ring M6	125Z-6 6
10	Verplaatsingsplaat rempomp	1
11	Schroefborging	1
12	Montagearm	1

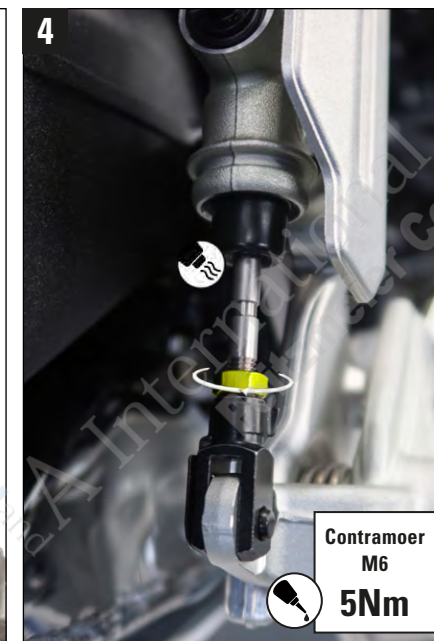
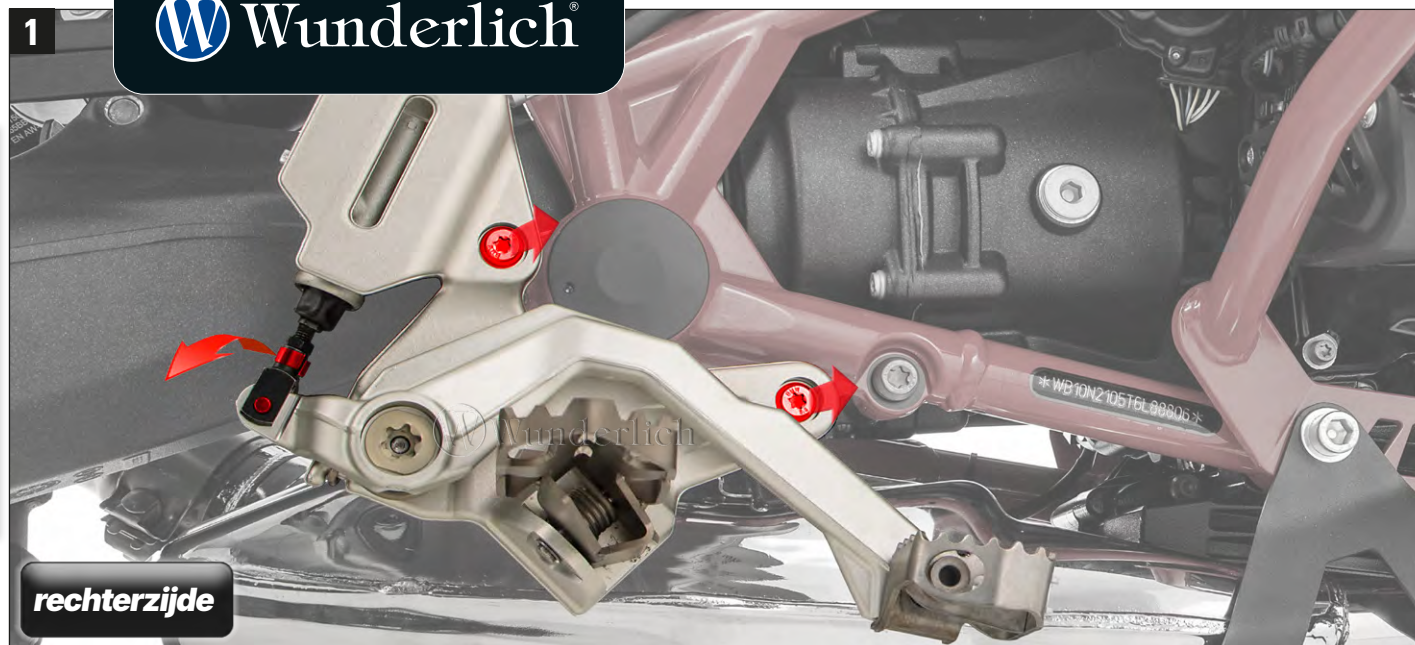

! De montage mag alleen worden uitgevoerd door geschoolde en deskundige personen, of in een gespecialiseerde werkplaats.
Na de montage het achterwiel controleren op vrije beweging, indien nodig drukpen/remhendel afstellen (speling 1,3 mm)

5



6

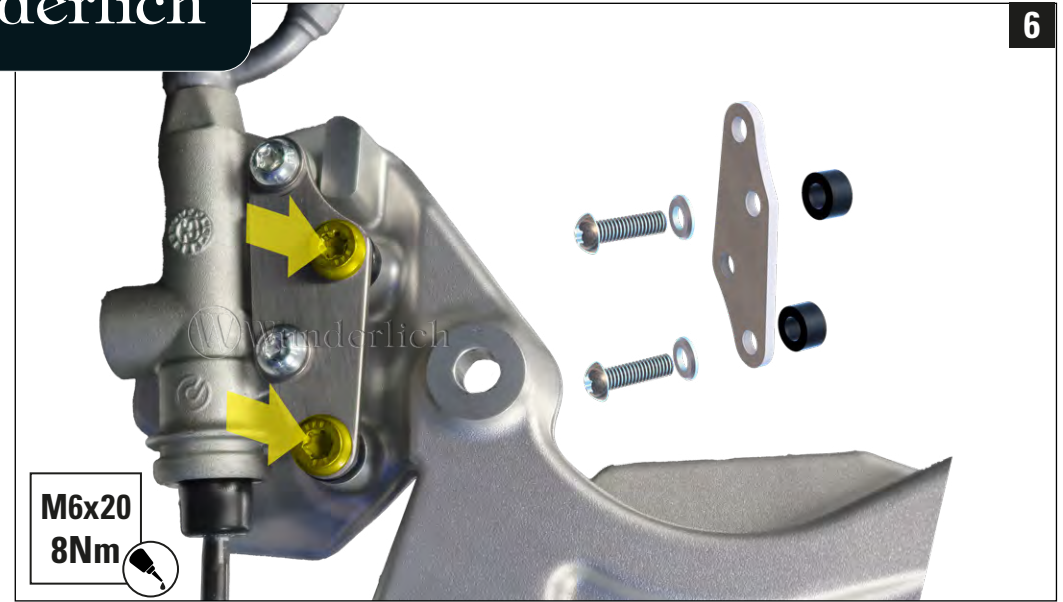

7

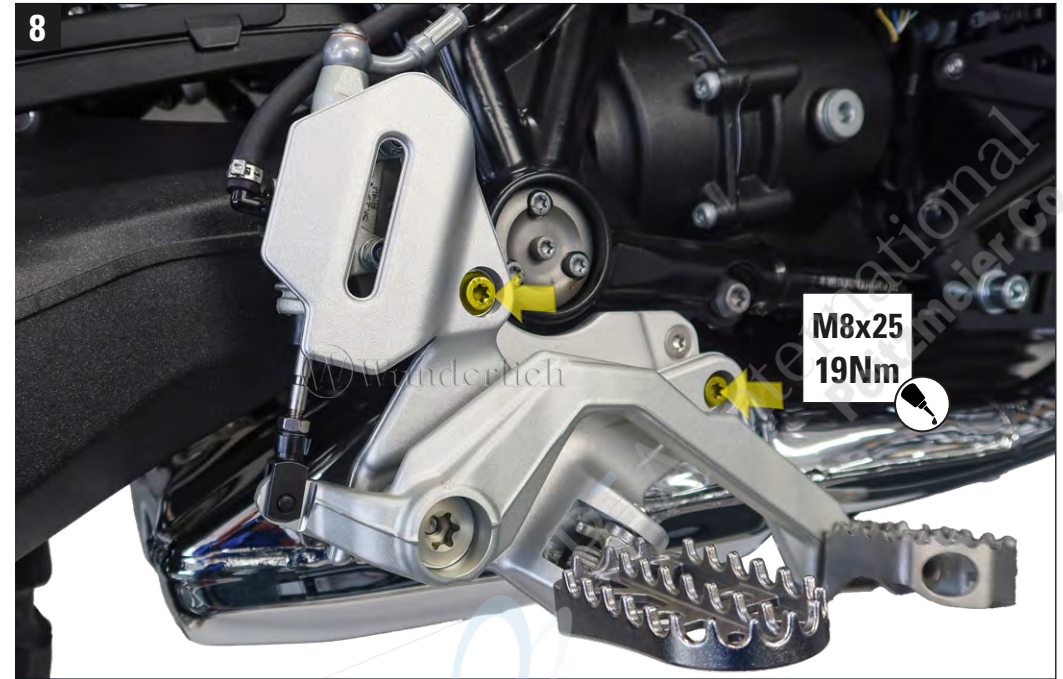
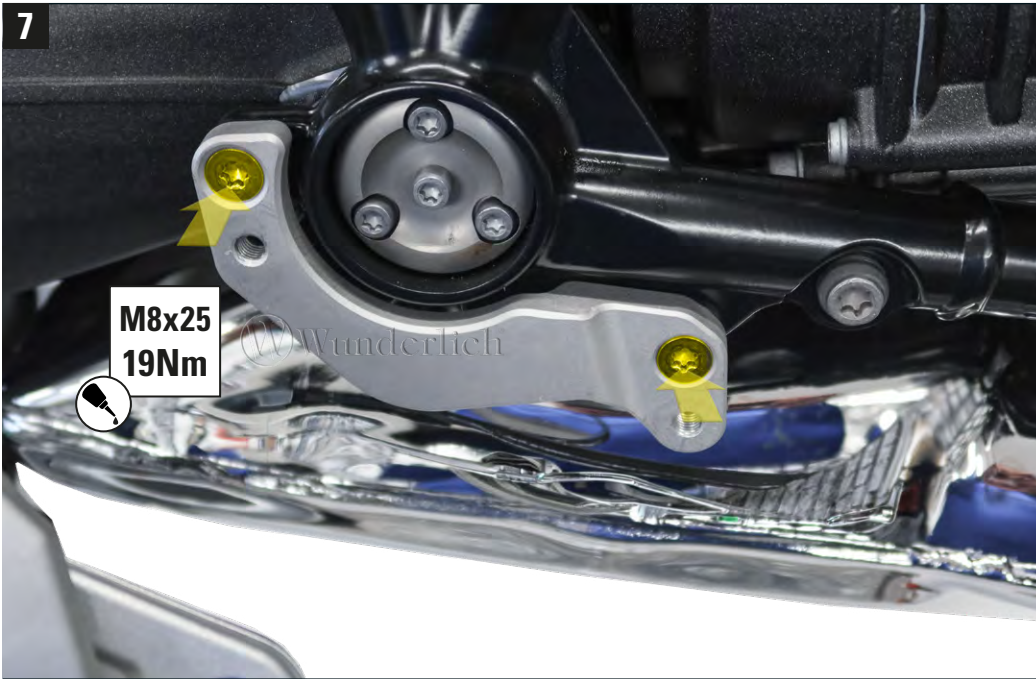

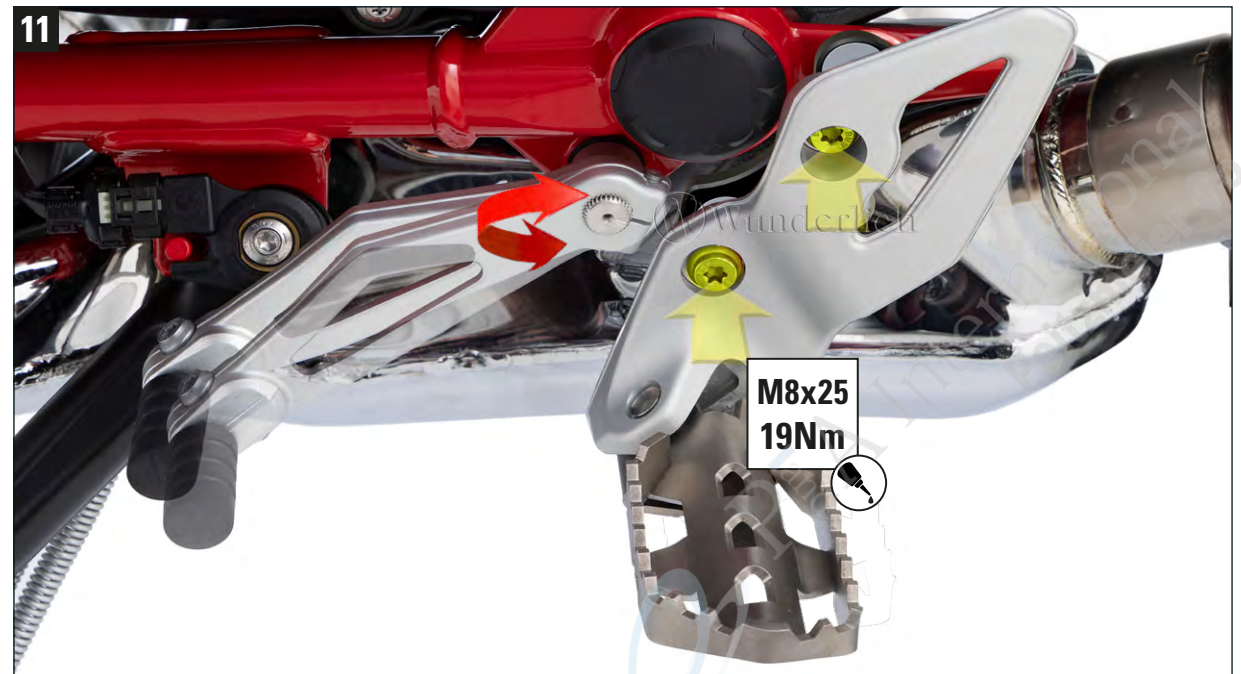
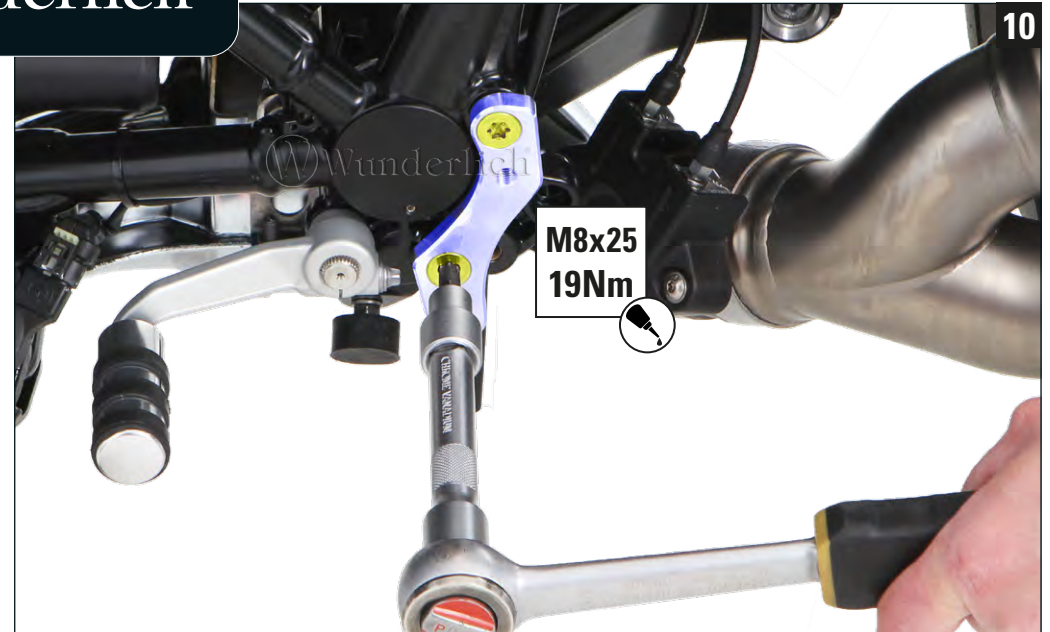

Schakelpedaal afstellen!



Drogi Kliencie, dziękujemy za zaufanie i zakup produktu Wunderlich.

Niniejsza instrukcja montażu wspiera Cię w bezpiecznej i fachowej instalacji Twojego produktu.

Ważna uwaga

Prosimy o przeczytanie tej instrukcji w całości przed rozpoczęciem montażu.

Wsparcie

W przypadku pytań podczas montażu, prosimy o kontakt z naszym wsparciem przed rozpoczęciem prac:

Tel.: +49 2641-3082-240

E-Mail: support@wunderlich.de

Życzymy Ci wiele radości z produktu Wunderlich i zawsze bezpiecznej jazdy.

Twój #TeamWunderlich



#31431-00x

Przesunięcie podnóżków

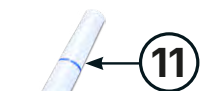

11



12

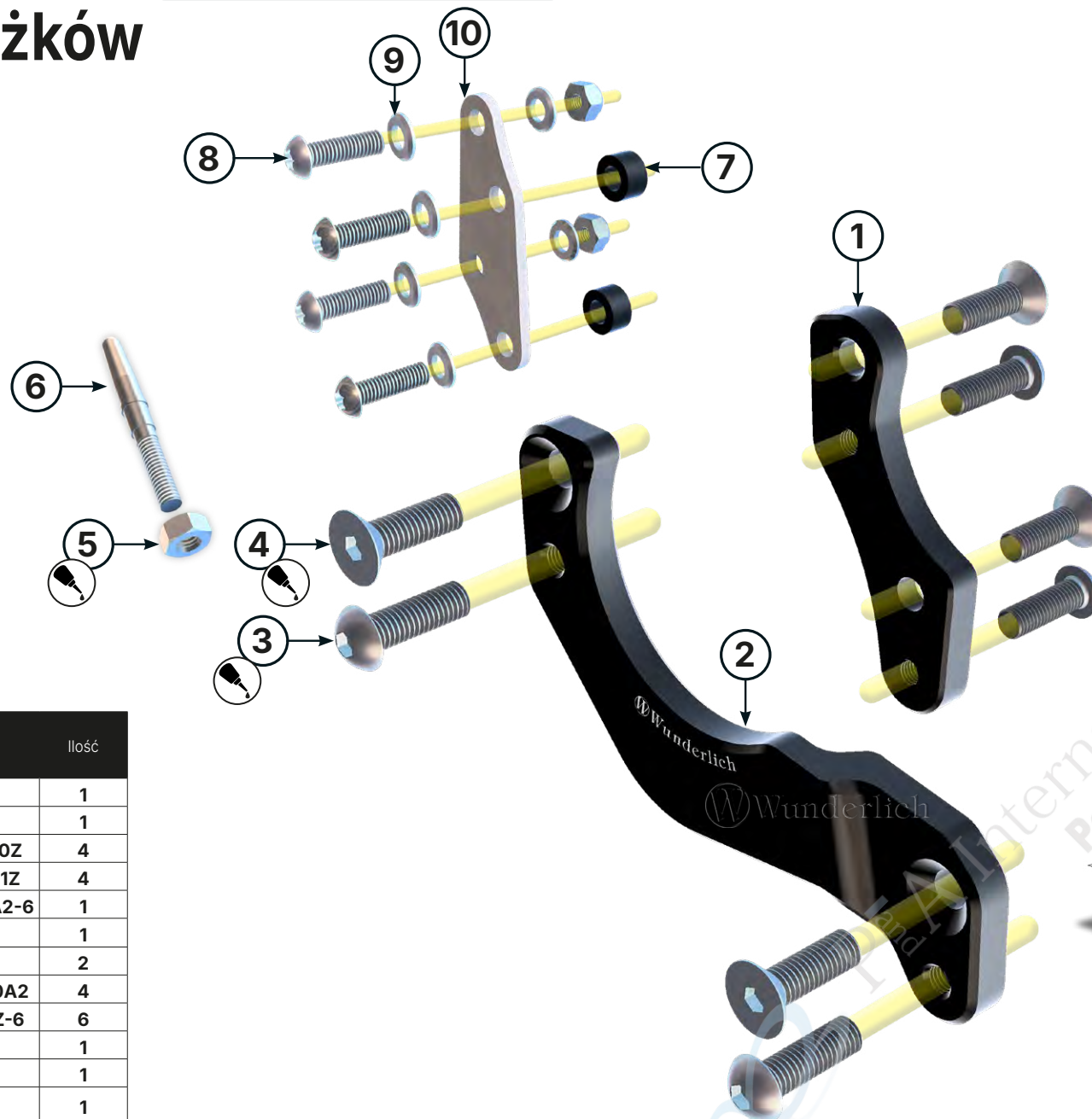

Legenda



Część

Kolory ilustracji służą wyłącznie do celów poglądowych.

Ilość

#	Część		Ilość
1	Przesunięcie podnóżków lewa strona		1
2	Przesunięcie podnóżków prawa strona		1
3	Śruba z łbem soczewkowym M8×25	7380Z	4
4	Śruba stożkowa M8×25	7991Z	4
5	Nakrętka sześciokątna M6	934A2-6	1
6	Sworzeń dociskowy		1
7	Tuleja ØD 13,0 - Ød 7,0 - h 7,0 mm		2
8	Śruba z łbem soczewkowym M6×20	7380A2	4
9	Podkładka M6	125Z-6	6
10	Płyta montażowa pompy hamulcowej		1
11	Zabezpieczenie śrub		1
12	Gałąź montażowa		1

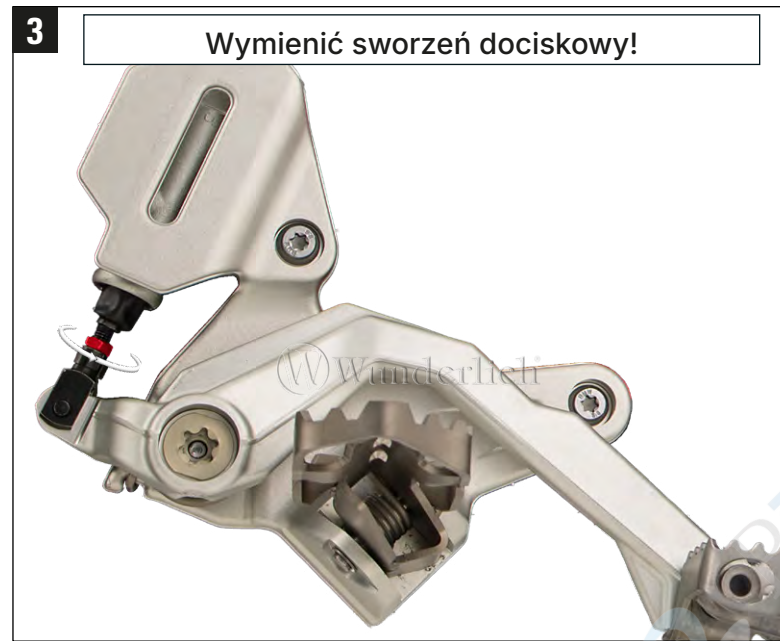
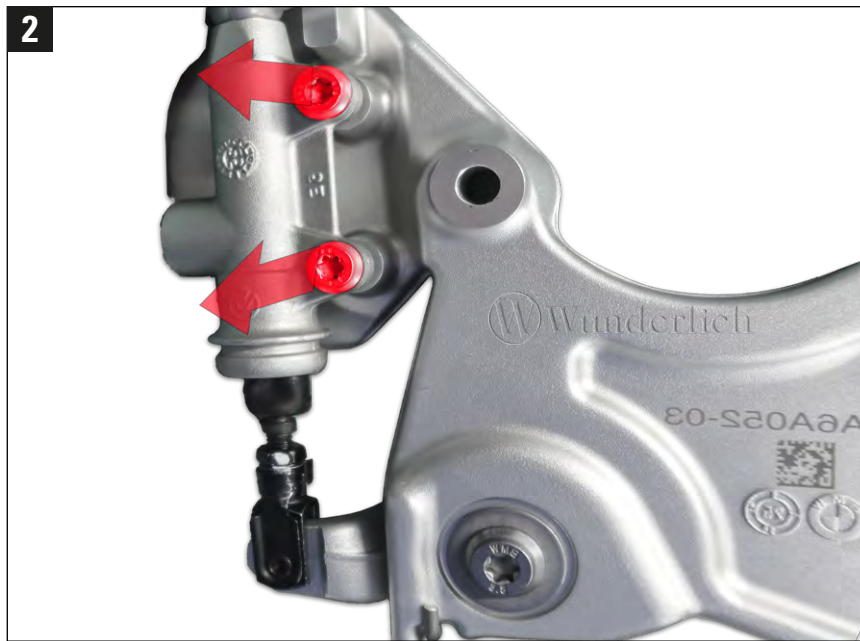
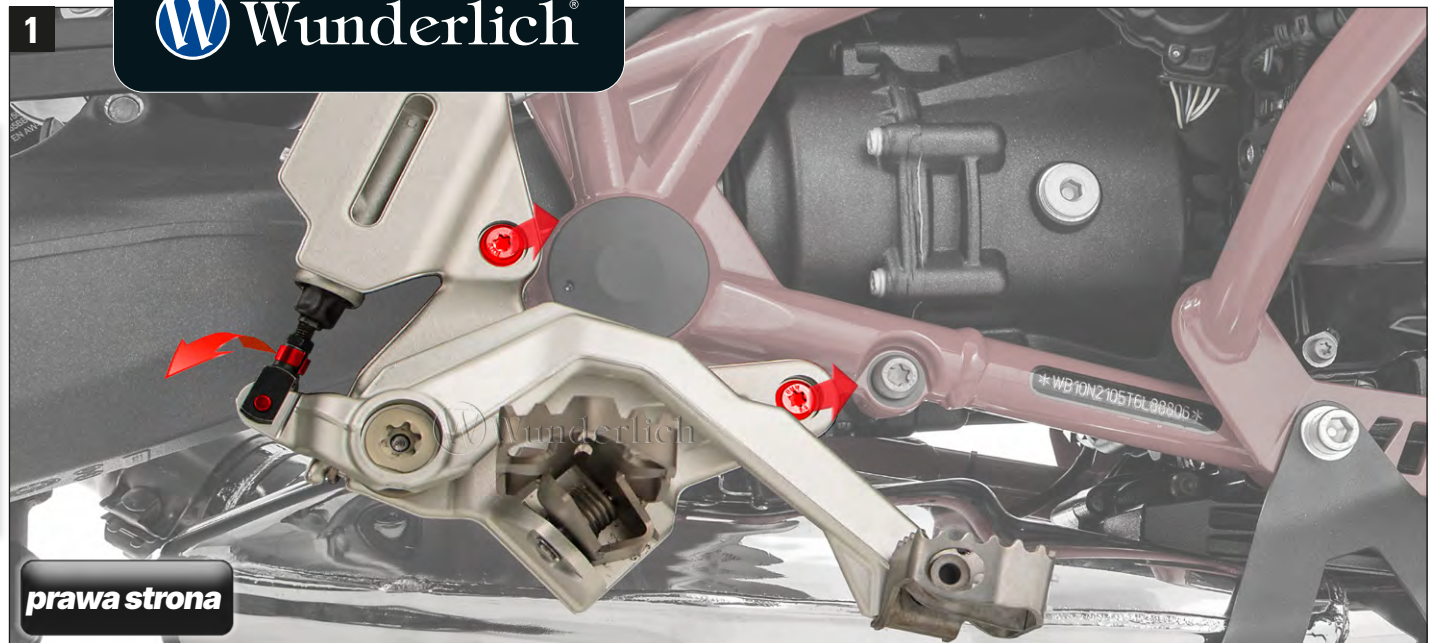

Montaż może być przeprowadzony tylko przez przeszkolone i kompetentne osoby lub w specjalistycznym warsztacie.
Po montażu sprawdzić swobodę ruchu tylnego koła, w razie potrzeby wyregulować sworzeń dociskowy / dźwignię hamulca (luz 1,3 mm)

5



6

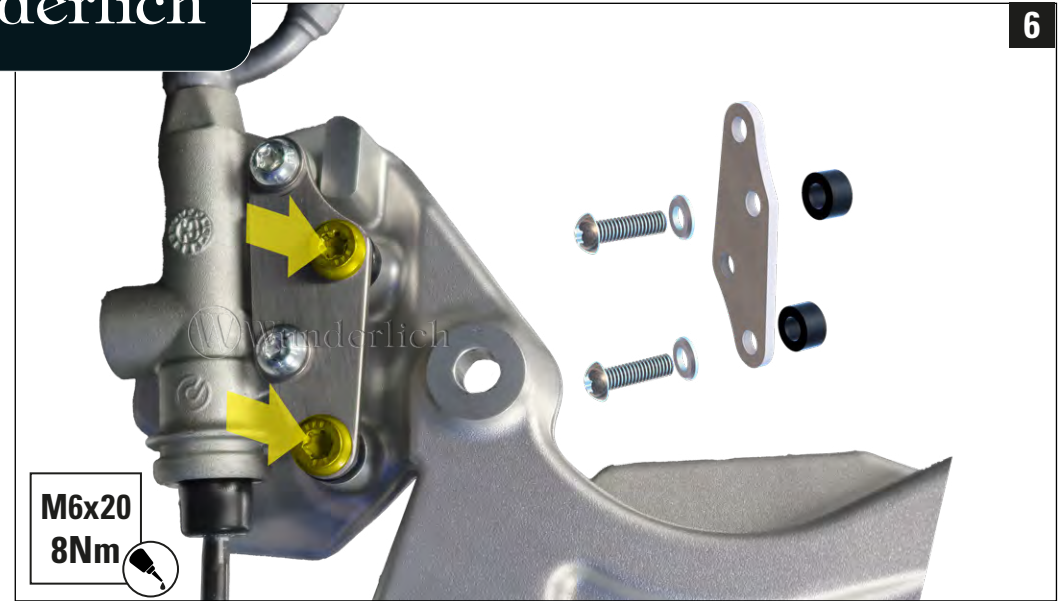

7

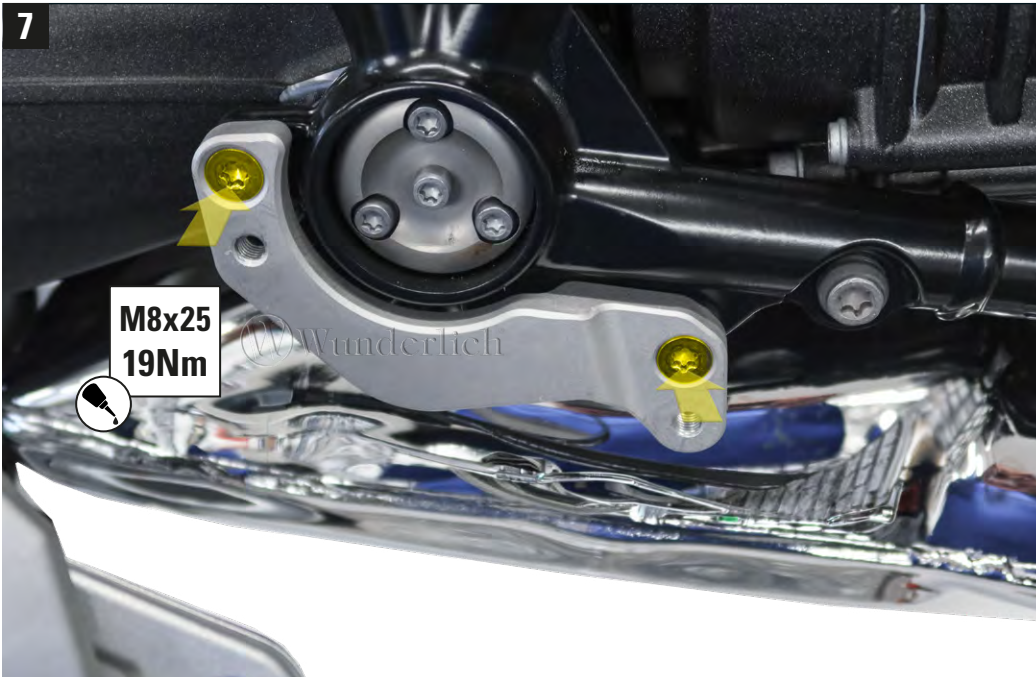

8





Wyregulować dźwignię zmiany biegów!



Milý zákazníku, děkujeme za vaši důvěru a nákup tohoto produktu Wunderlich.

Tato montážní příručka vás podpoří při bezpečné a odborné instalaci vašeho produktu.

Důležité upozornění

Před zahájením montáže si prosím tuto příručku přečtěte úplně.

Podpora

Pokud se během montáže vyskytnou otázky, obraťte se prosím před zahájením prací na naši podporu:

Tel.: +49 2641-3082-240

E-mail: support@wunderlich.de

Přejeme vám hodně radosti s vaším produktem Wunderlich a vždy šťastnou cestu.

Váš #TeamWunderlich



#31431-00x

Posunutí stupaček levá strana

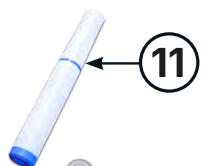

11



12

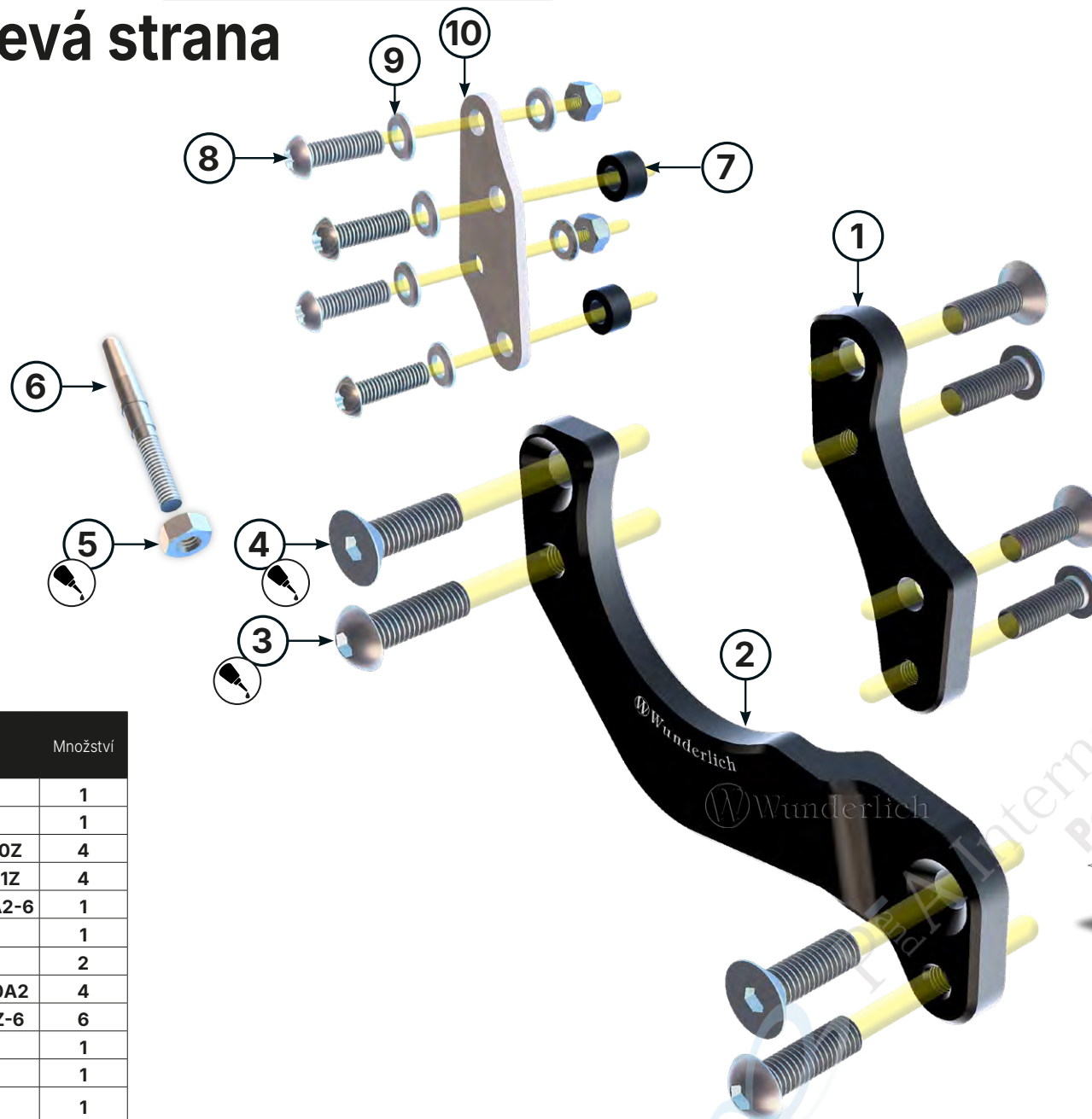

Legenda

- Tip pro montáž
- Pozor
- Zvětšení
- Montážní pasta
- Šroub
- Zajištění šroubů
- Uťahovací moment
- Čistič

#	Součástka	Množství
1	Posunutí stupaček levá strana	1
2	Posunutí stupaček pravá strana	1
3	Šroub s čočkovou hlavou M8×25	7380Z 4
4	Zápustný šroub M8×25	7991Z 4
5	Šestihranná matice M6	934A2-6 1
6	Tlakový čep	1
7	Pouzdro ØD 13,0 - Ød 7,0 - h 7,0 mm	2
8	Šroub s čočkovou hlavou M6×20	7380A2 4
9	Podložka M6	125Z-6 6
10	Montážní plech brzdové pumpy	1
11	Zajištění šroubů	1
12	Montážní pasta	1

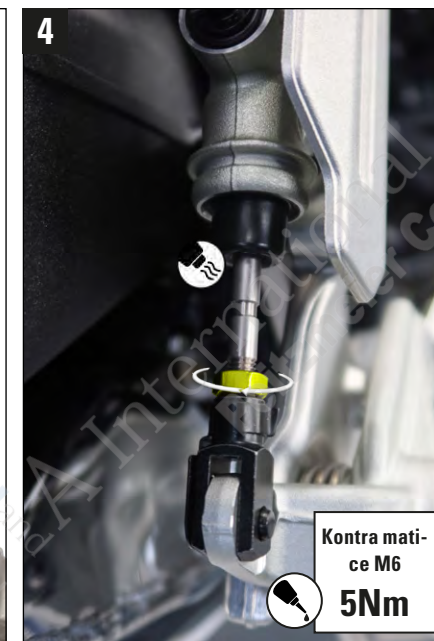
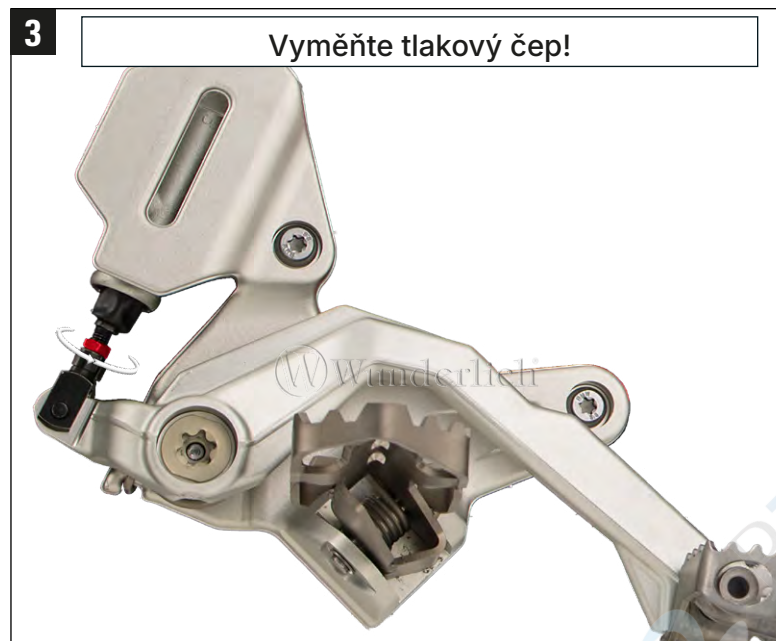
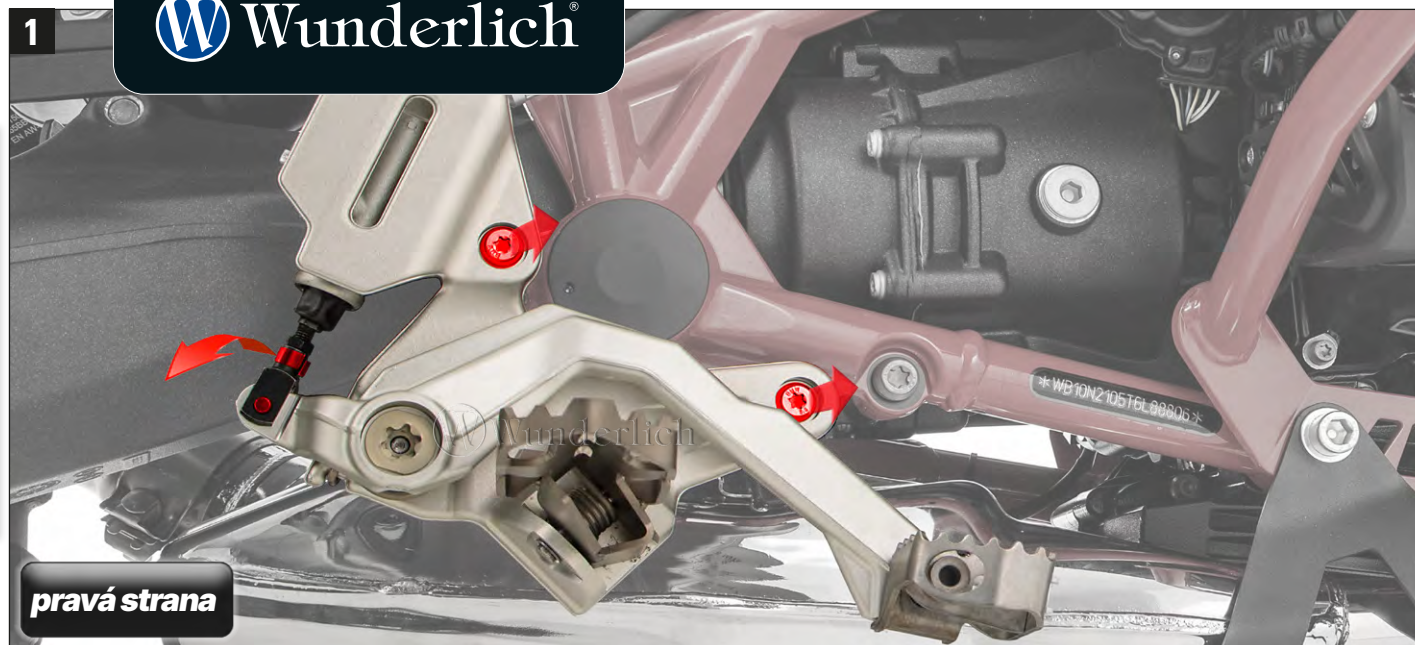

Montáž smí provádět pouze školené a odborné osoby nebo odborná dílna.
Po montáži zkontrolujte volnost zadního kola, případně nastavte tlakový čep / brzdovou páku (mezera 1,3 mm)

5



6

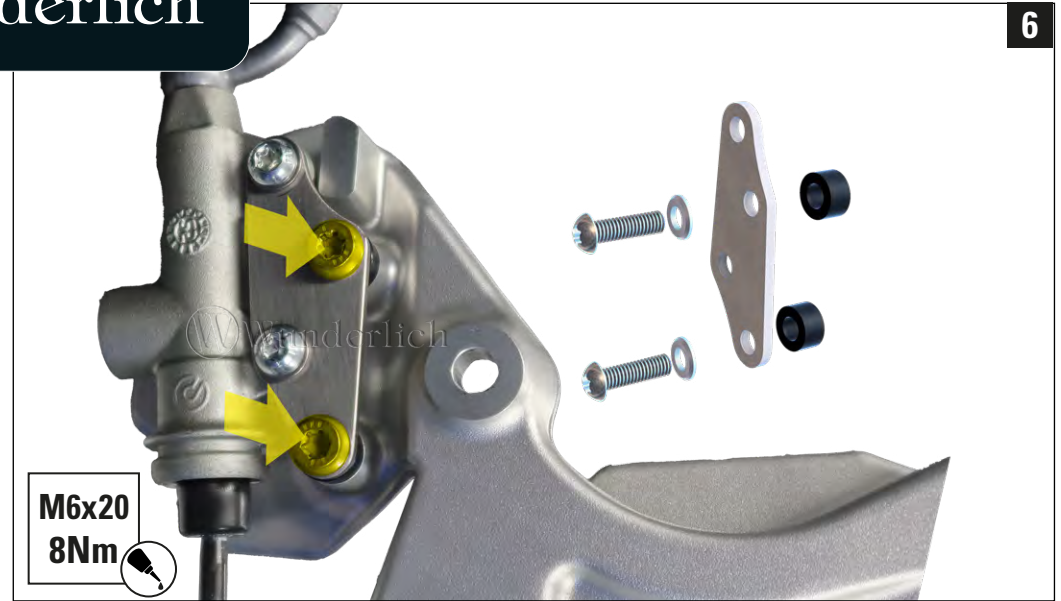

7

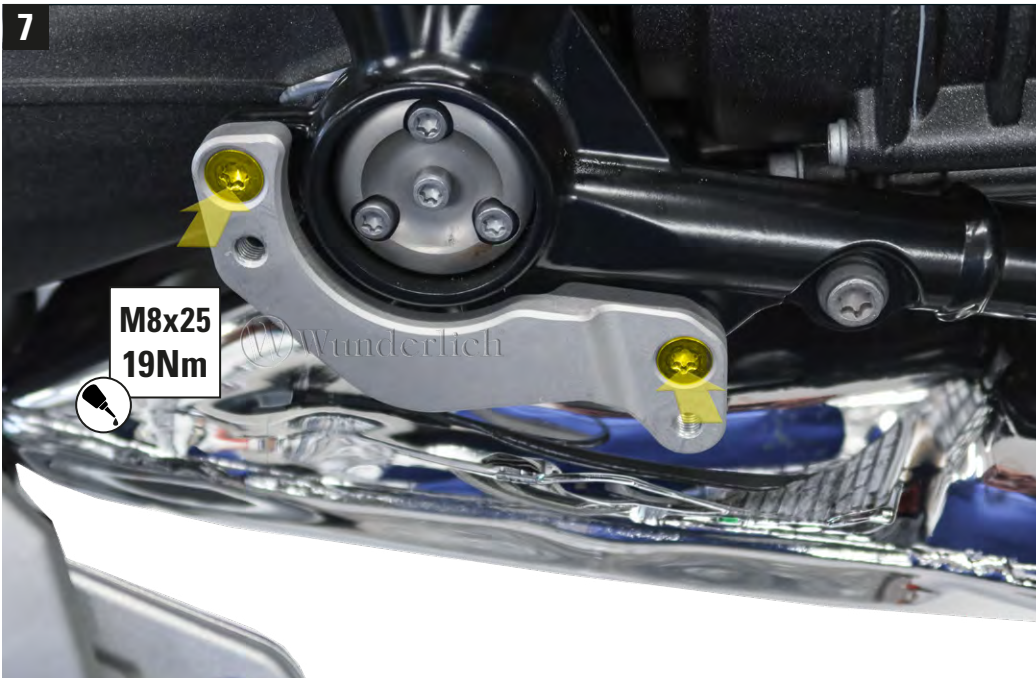

8

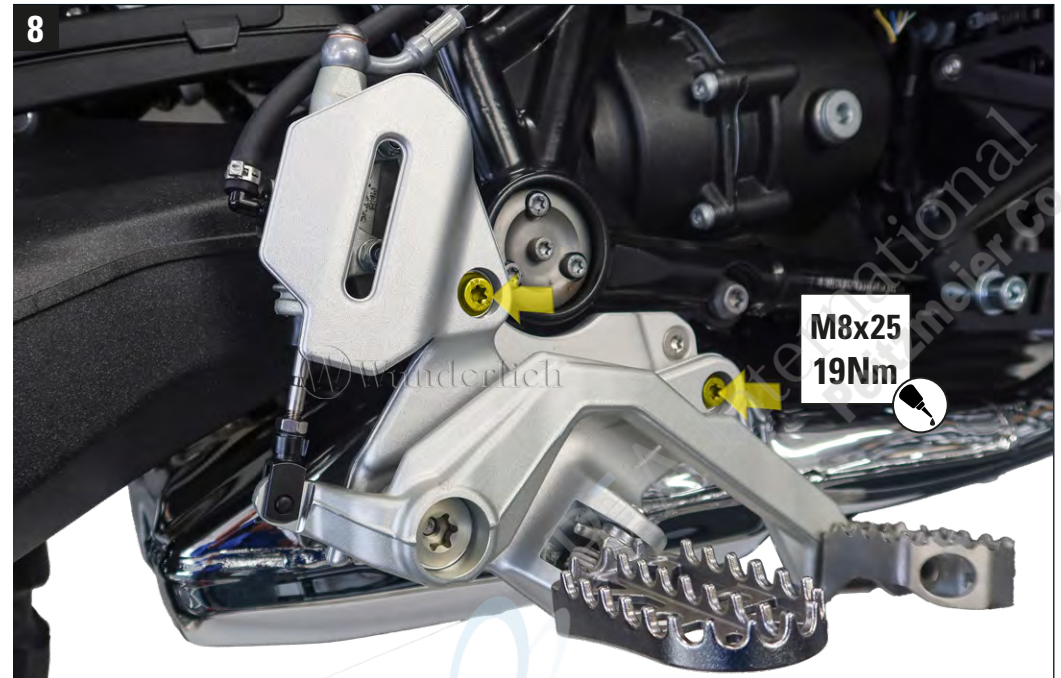

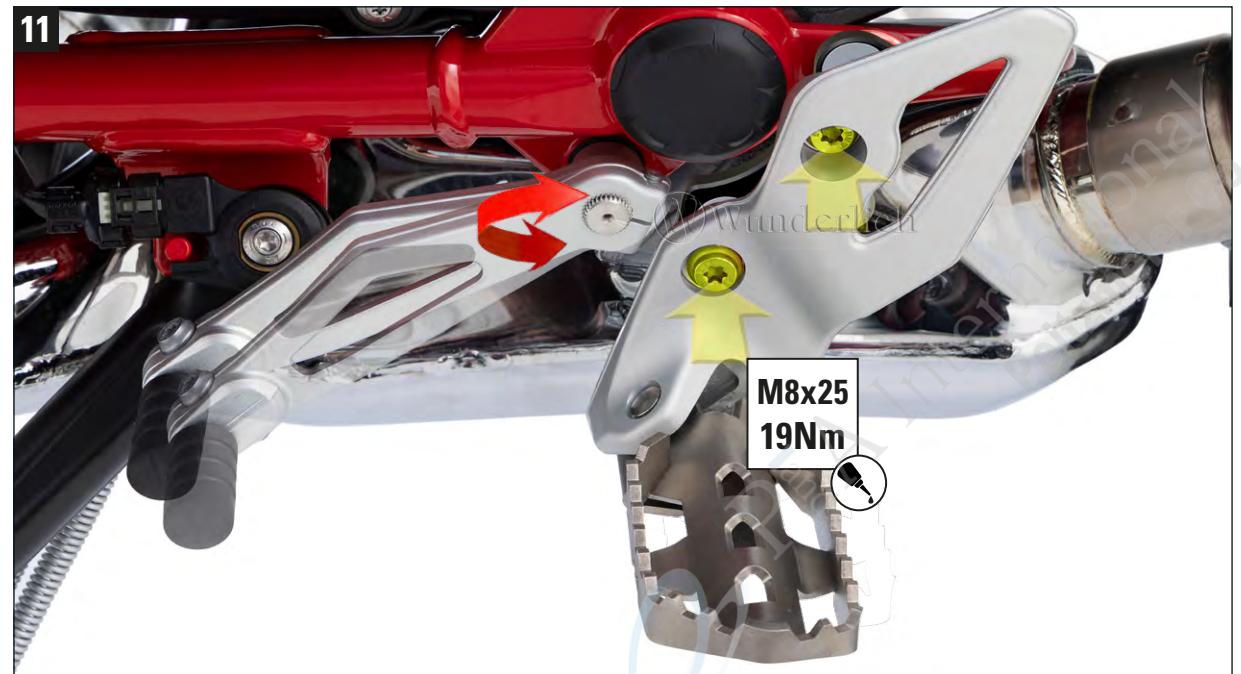
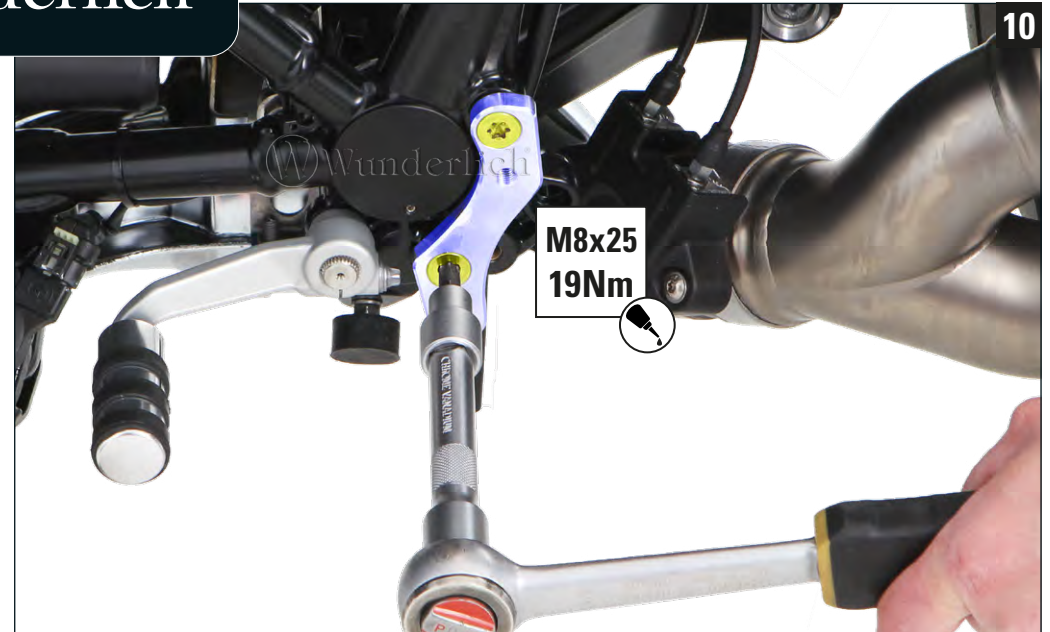

Nastavte řadicí páku!



Kära kund, tack för ditt förtroende och för att du har köpt denna Wunderlich-produkt.

Denna monteringsanvisning hjälper dig med en säker och korrekt installation av din produkt.

Viktig anmärkning

Läs denna anvisning noggrant innan du börjar med monteringen.

Support

Om du har frågor under monteringen, vänligen kontakta vår support innan du börjar arbetet:

Tel.: +49 2641-3082-240

E-post: support@wunderlich.de

Vi önskar dig mycket glädje med din Wunderlich-produkt och alltid en säker resa.

Ditt #TeamWunderlich



#31431-00x

Fotplacering

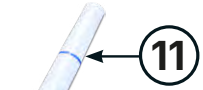

Legend

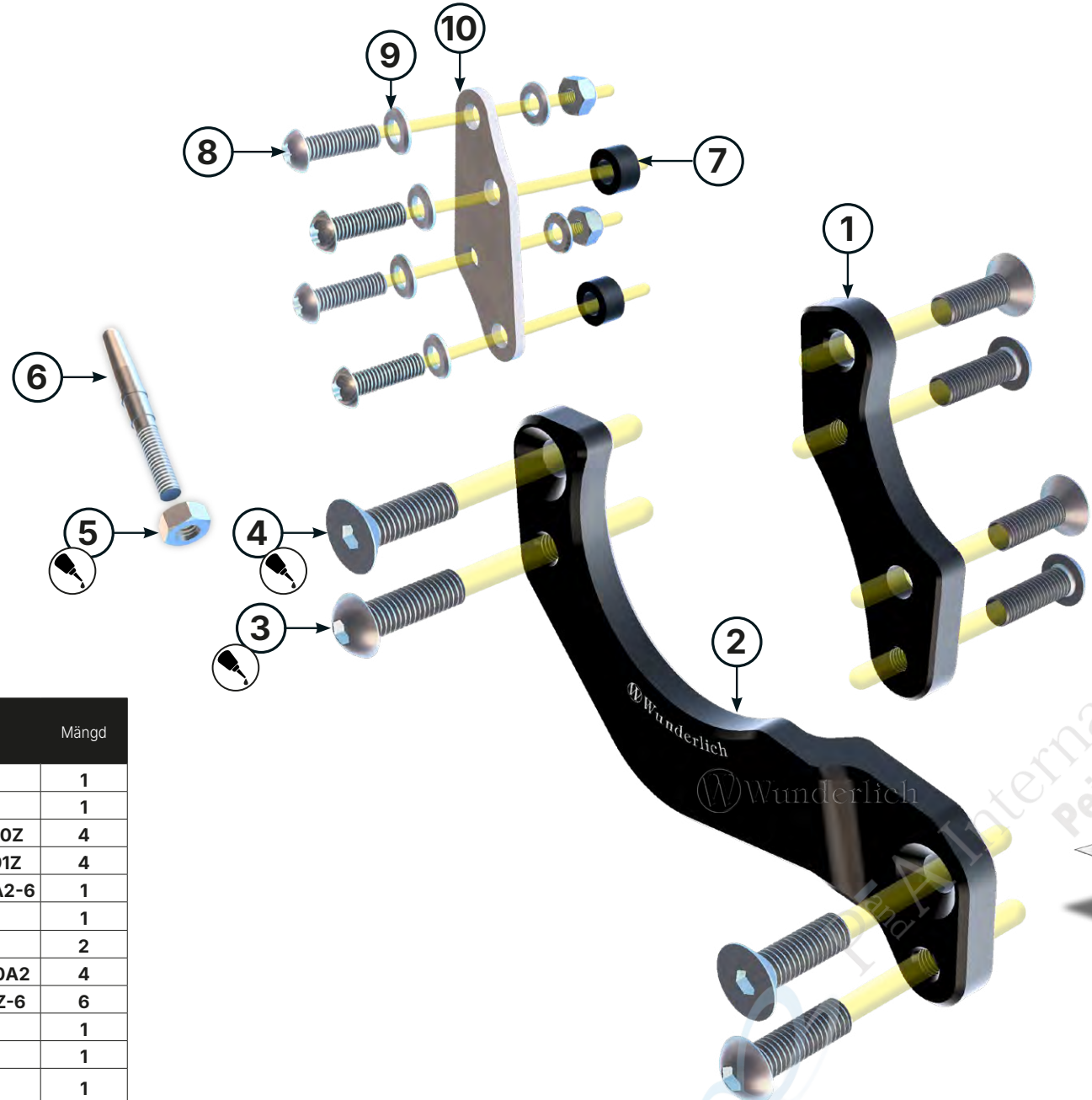
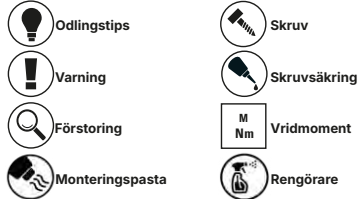

#	Komponent	Mängd
	Färgerna på bilderna är endast för illustration.	
1	Flyttning av rastplats till vänster sida	1
2	Flyttning av rastplats till höger sida	1
3	Linseskruv M8×25	7380Z 4
4	Sänkskruv M8×25	7991Z 4
5	Sexkantmutter M6	934A2-6 1
6	Tryckbult	1
7	Hylsa ØD 13,0 - Ød 7,0 - h 7,0 mm	2
8	Linseskruv M6×20	7380A2 4
9	Bricka M6	125Z-6 6
10	Bromspumpens monteringsplåt	1
11	Skrivsäck	1
12	Montagearbetare	1

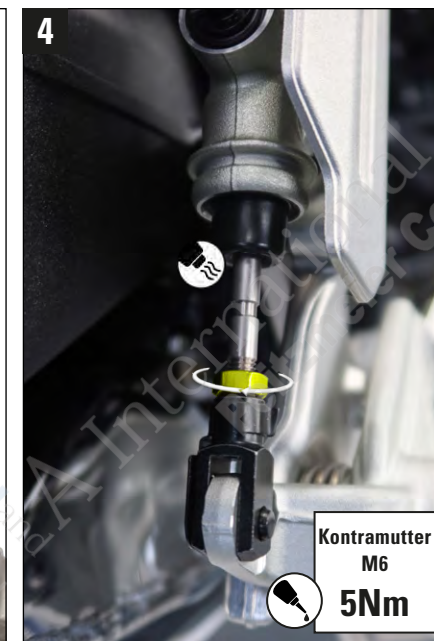
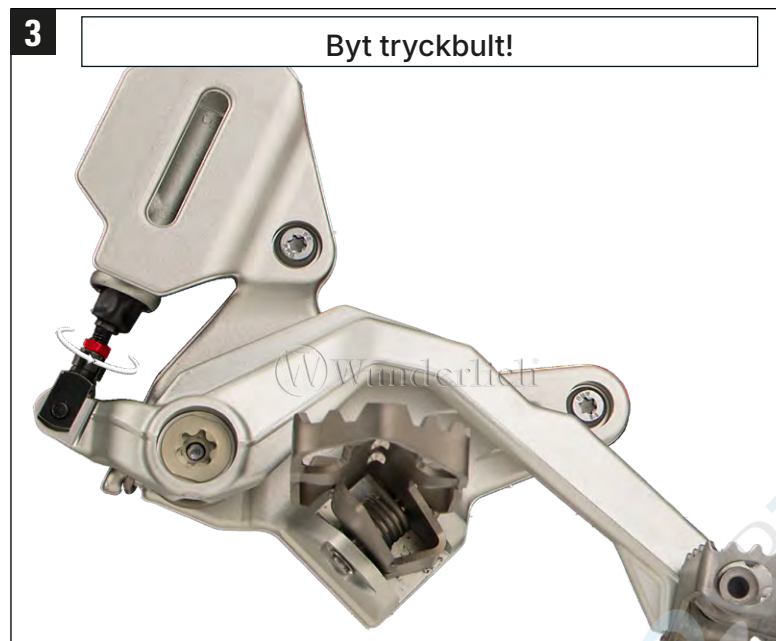
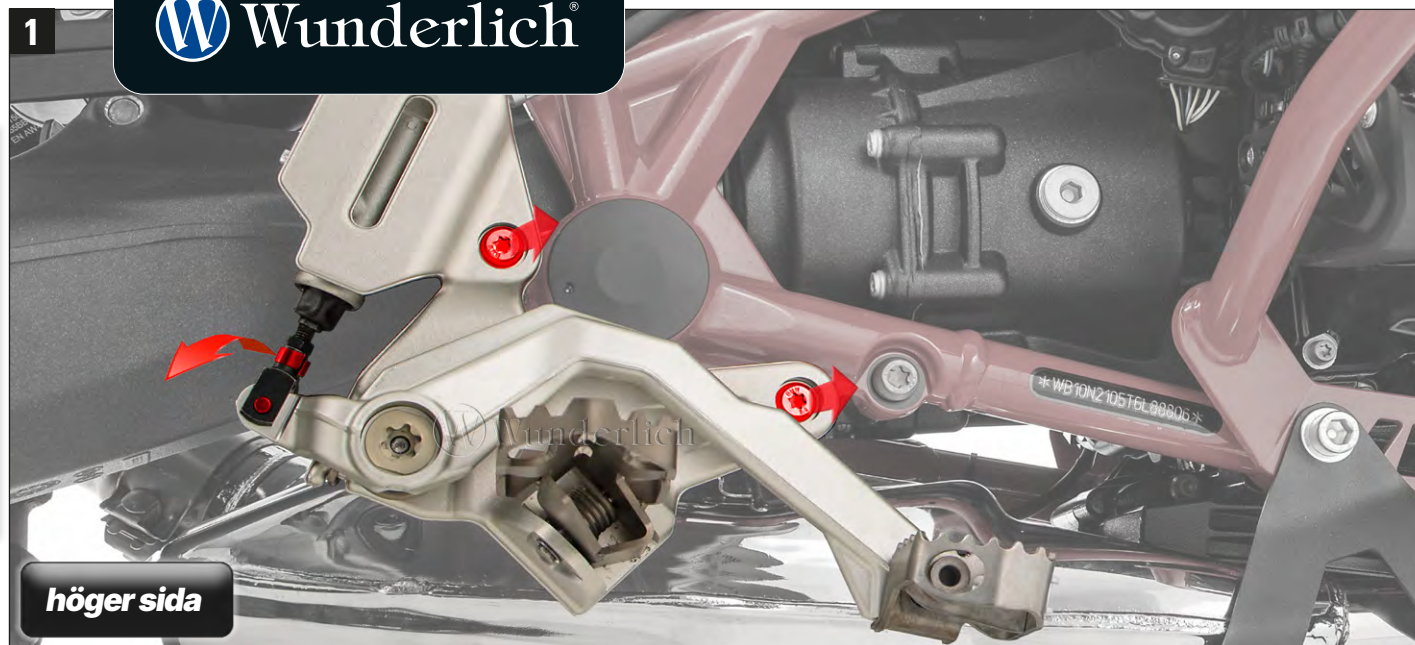

⚠ Monteringen får endast utföras av utbildad och kunnig personal eller på en fackverkstad.
Efter monteringen kontrollera att bakhjulet rör sig fritt, justera vid behov tryckbult/bromsarm (spaltmått 1,3 mm).

5



6

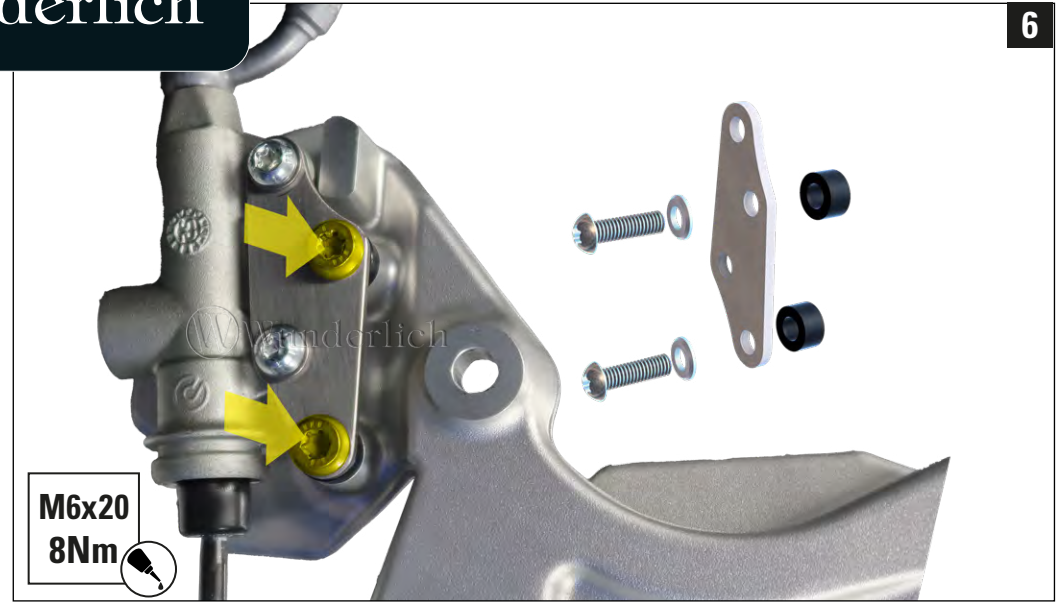

7

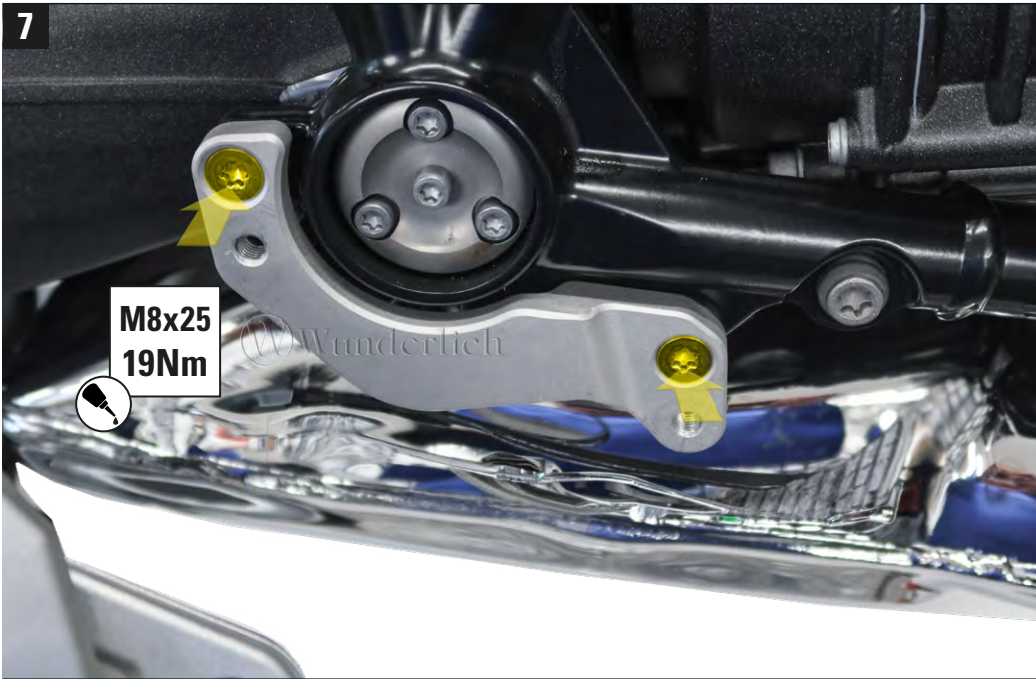

8

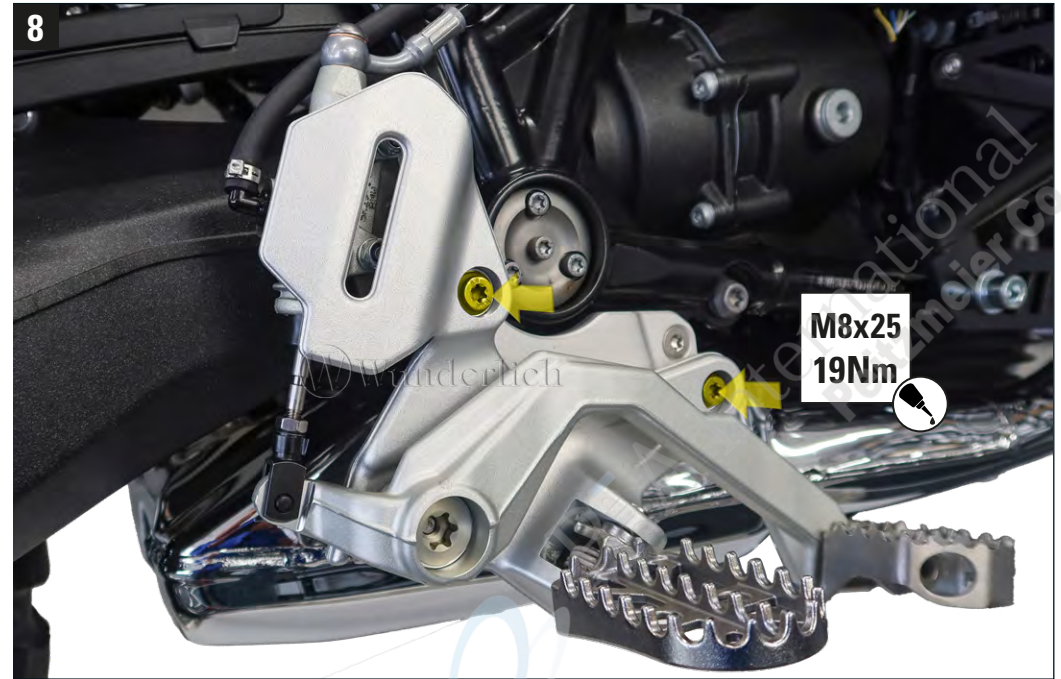

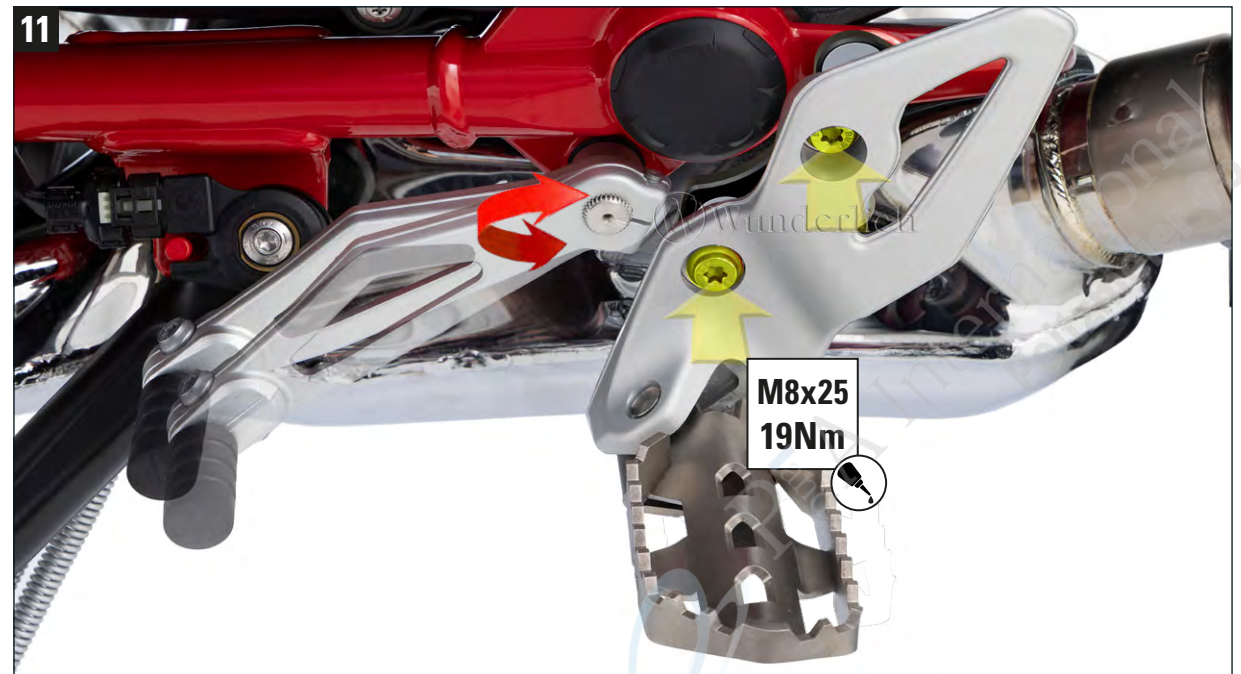

Justera växelspaken!



Kjære kunde, takk for din tillit og kjøpet av dette Wunderlich-produktet.

Denne monteringsanvisningen hjelper deg med sikker og korrekt installasjon av produktet ditt.

Viktig merknad

Vennligst les denne anvisningen i sin helhet før du begynner monteringen.

Support

Hvis det oppstår spørsmål under monteringen, vennligst kontakt vår support før du begynner arbeidet:

Tel.: +49 2641-3082-240

E-post: support@wunderlich.de

Vi ønsker deg mye glede med ditt Wunderlich-produkt og alltid en god tur.

Ditt #TeamWunderlich



#31431-00x

Fotstøtteforlengelse

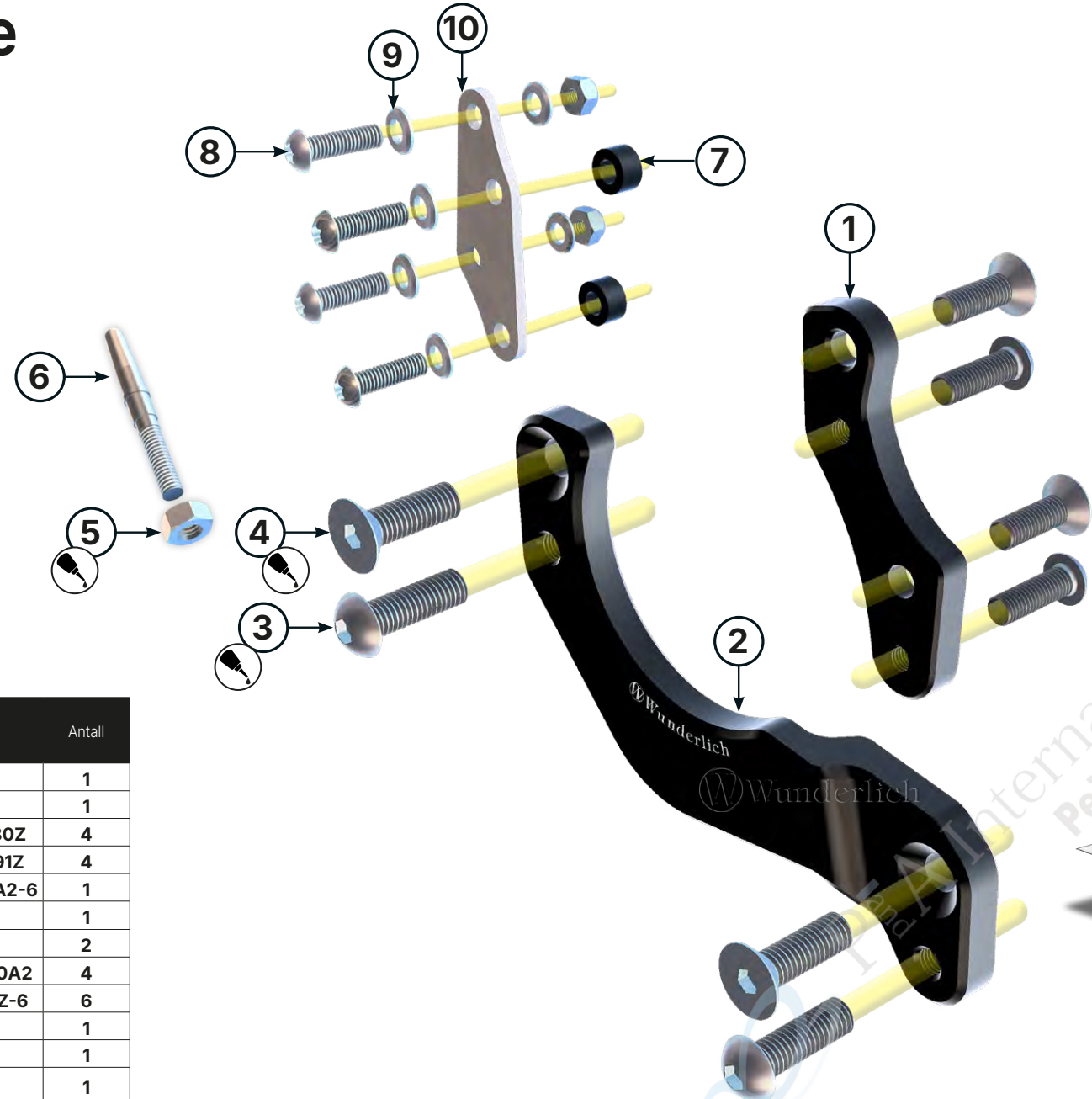
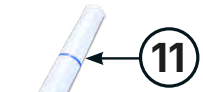

Legende



#	Komponent		Antall
	Fargene på illustrasjonene er kun for illustrasjonsformål.		
1	Forlengelse venstre side		1
2	Forlengelse høyre side		1
3	Linsehodeskrue M8×25	7380Z	4
4	Senkskrue M8×25	7991Z	4
5	Sekskantmutter M6	934A2-6	1
6	Trykkbolt		1
7	Hylse ØD 13,0 - Ød 7,0 - h 7,0 mm		2
8	Linsehodeskrue M6×20	7380A2	4
9	Skive M6	125Z-6	6
10	Forlengelsesplate bremsepumpe		1
11	Skruelås		1
12	Monteringsarm		1

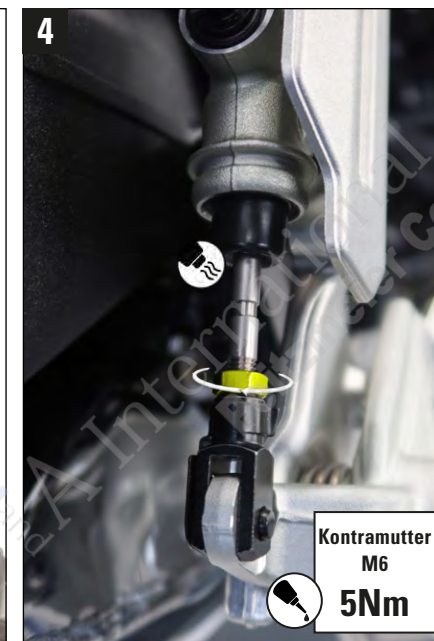
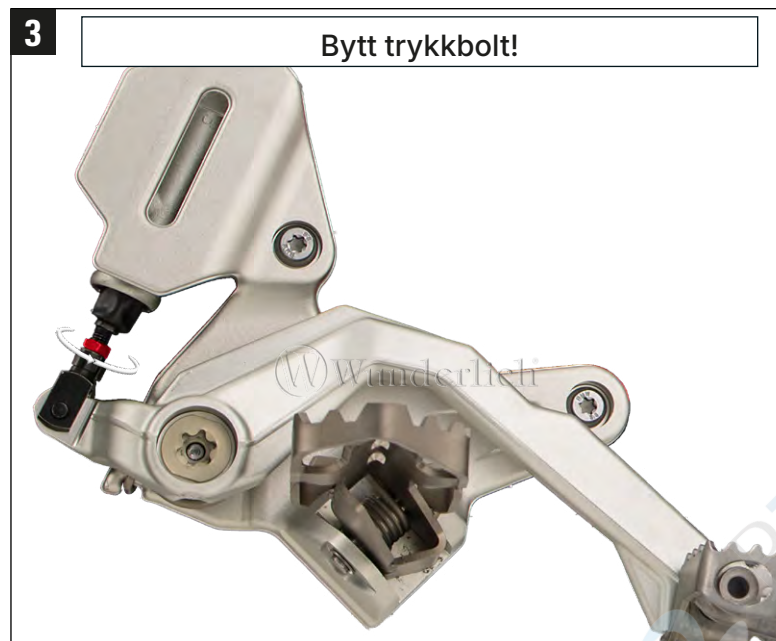
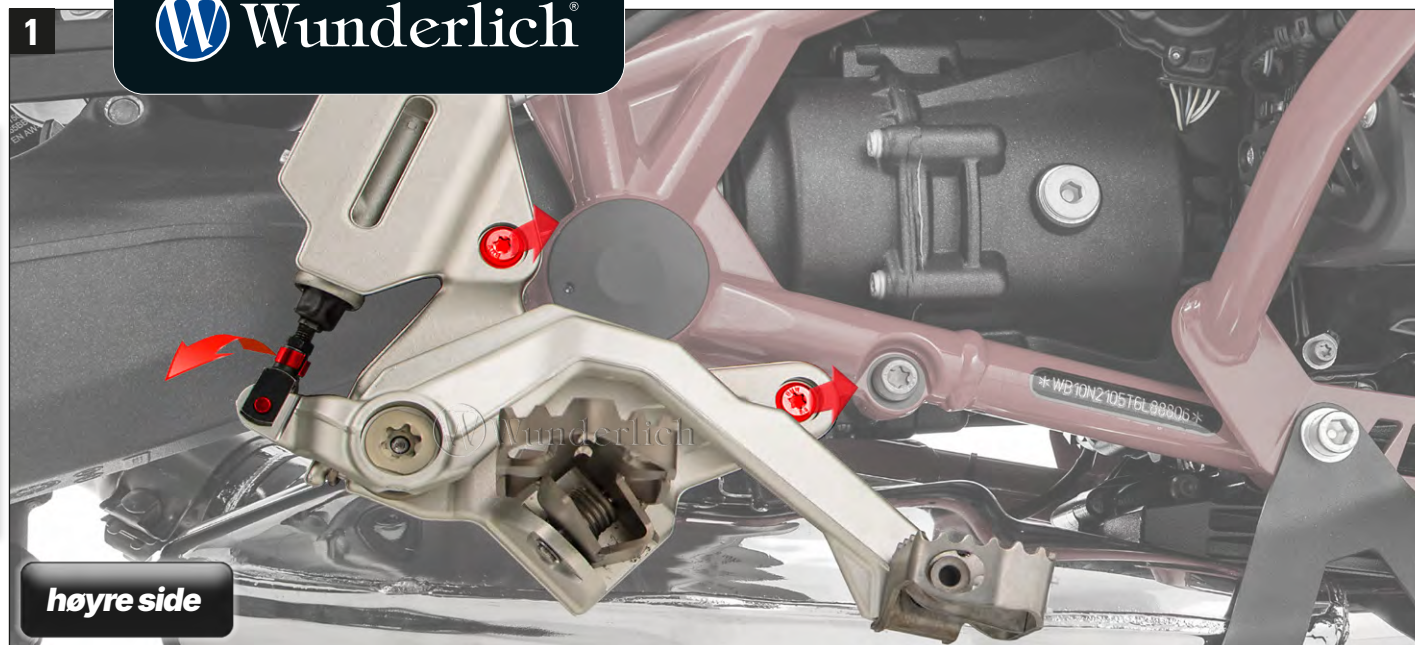

Monteringen må kun utføres av opplært og kyndig personell, eller på et verksted.
Etter montering, kontroller bakhjulet for fri bevegelse, juster trykkbolt / bremsepedal om nødvendig (spalte 1,3 mm)

5



6

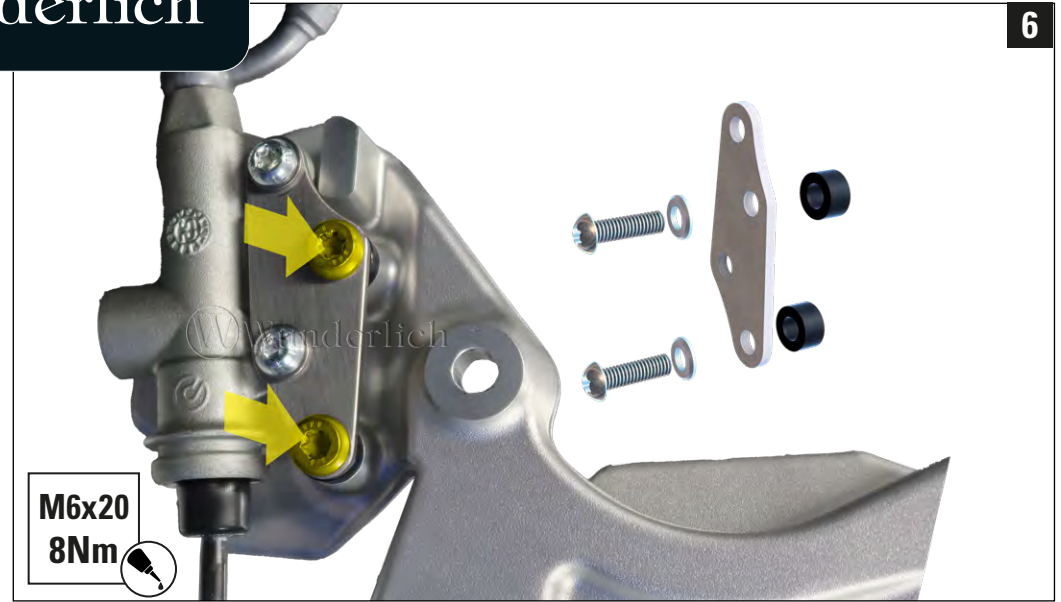

7

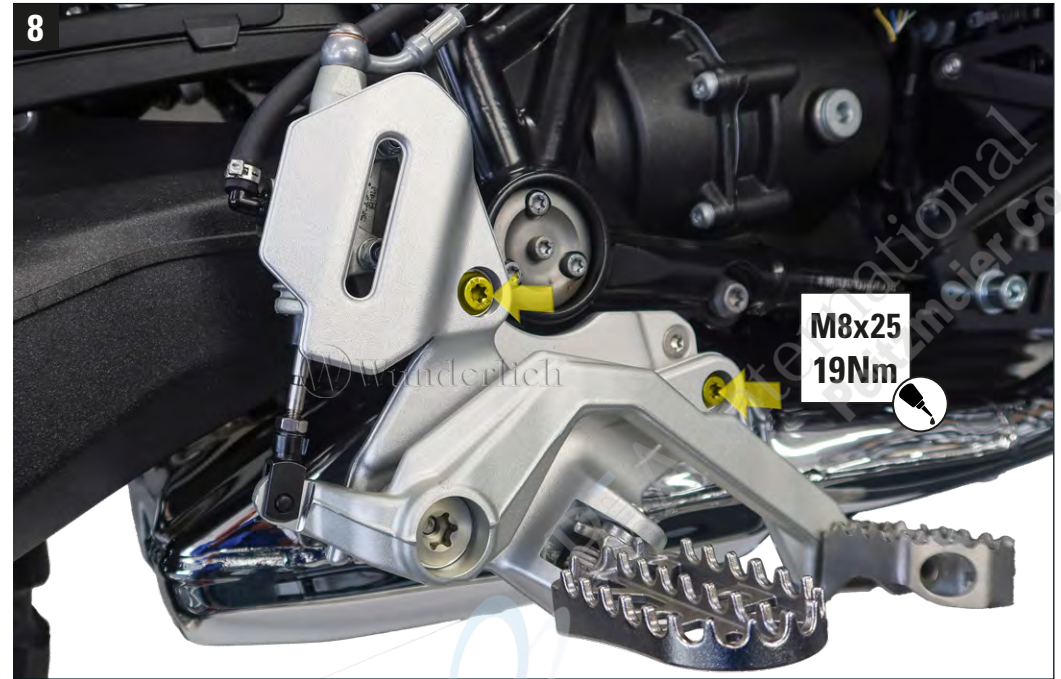
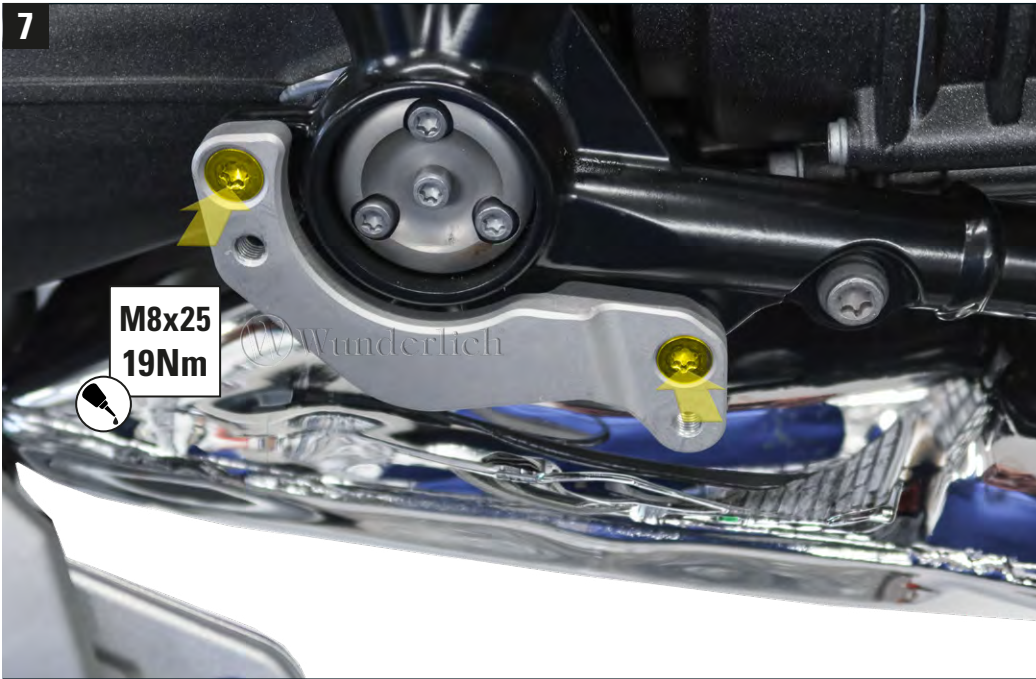

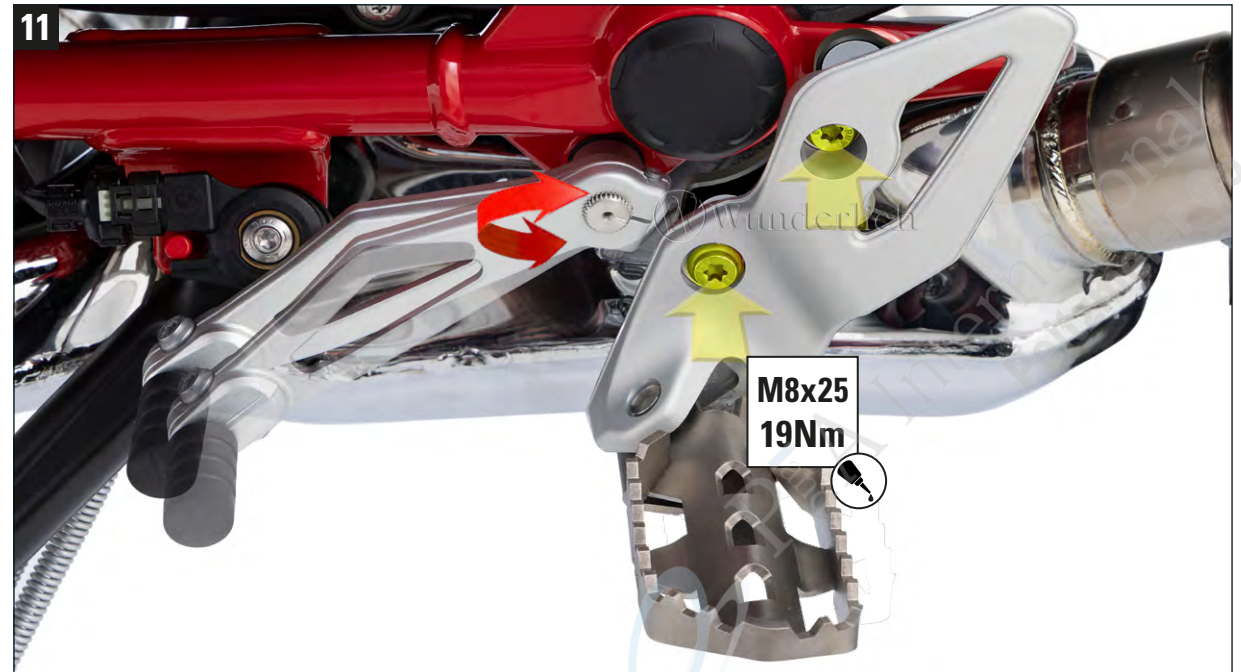

Juster girspaken!



Hyvä asiakas, kiitos luottamuksestanne ja tämän Wunderlich-tuotteen ostamisesta.

Tämä asennusohje auttaa teitä tuotteen turvallisessa ja asianmukaisessa asennuksessa.

Tärkeä huomautus

Lukekaa tämä ohje kokonaan ennen asennuksen aloittamista.

Tuki

Jos asennuksen aikana ilmenee kysymyksiä, ottakaa yhteyttä tukeemme ennen töiden aloittamista:

Puh.: +49 2641-3082-240

Sähköposti: support@wunderlich.de

Toivotamme teille paljon iloa Wunderlich-tuotteenne kanssa ja turvallisia ajomatkoja.

Teidän #TeamWunderlich



#31431-00x

Jalkatappien siirto

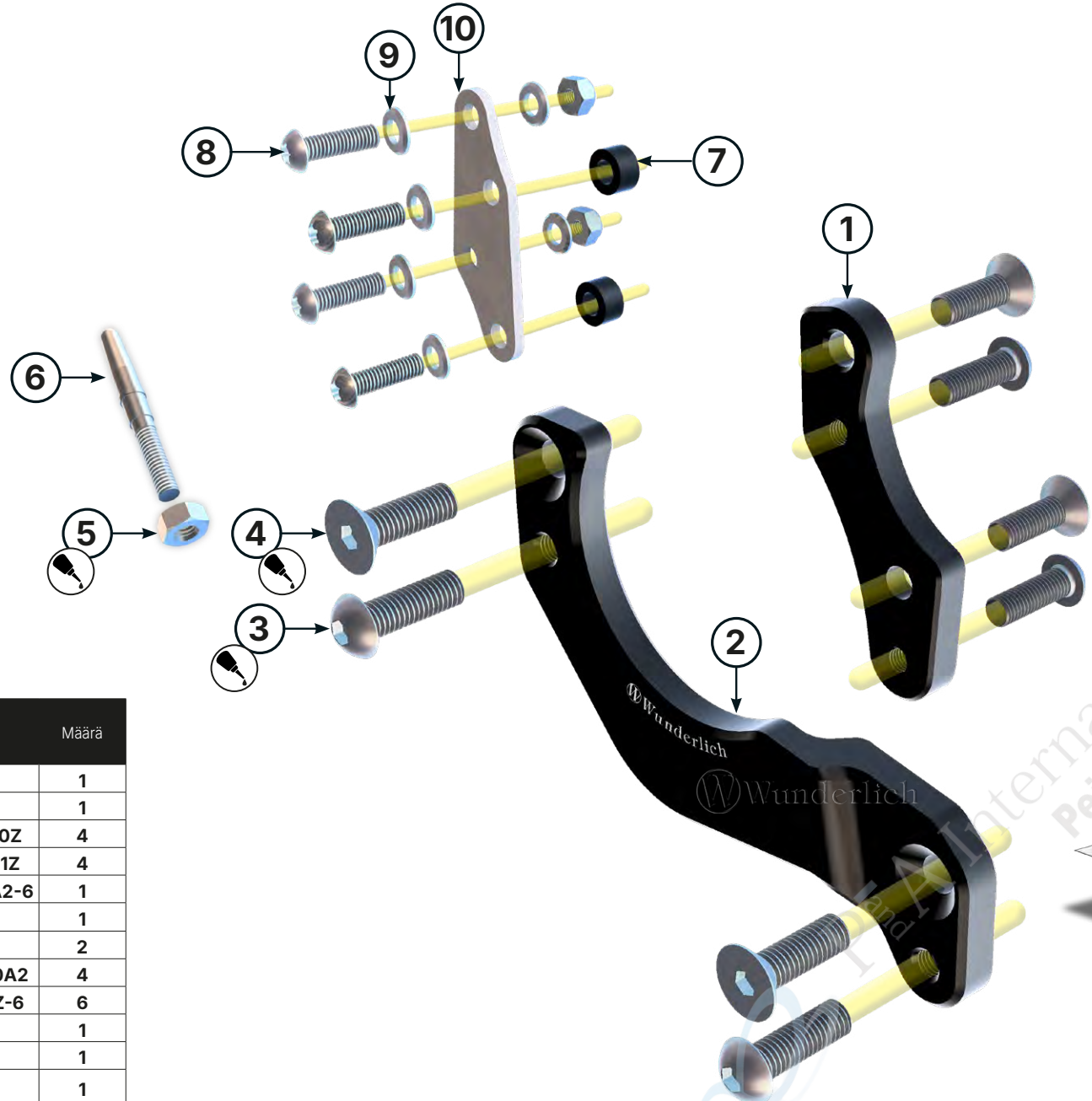
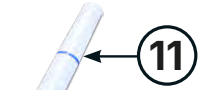

Legenda

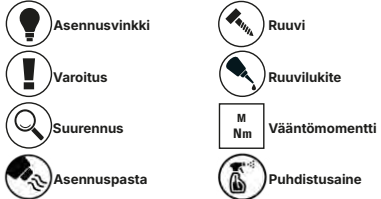

#	Komponentti	Määrä
1	Jalkatappien siirto vasen puoli	1
2	Jalkatappien siirto oikea puoli	1
3	Linssipääruuvi M8×25	7380Z 4
4	Upotettu ruuvi M8×25	7991Z 4
5	Kuusikulmoinen mutteri M6	934A2-6 1
6	Painepultti	1
7	Holkki ØD 13,0 - Ød 7,0 - h 7,0 mm	2
8	Linssipääruuvi M6×20	7380A2 4
9	Prikka M6	125Z-6 6
10	Jarrupumpun siirtopelti	1
11	Ruuvilukite	1
12	Asennusvarsi	1

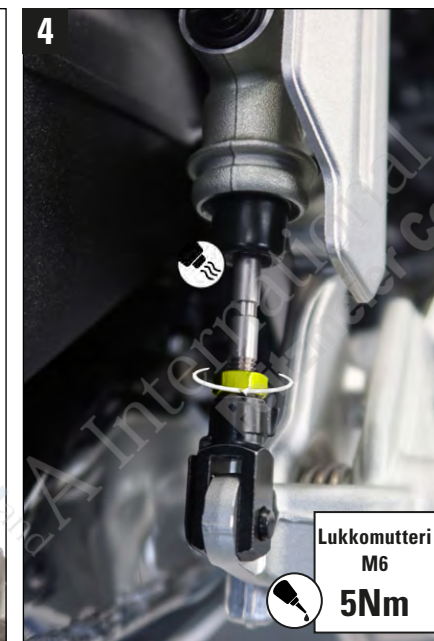
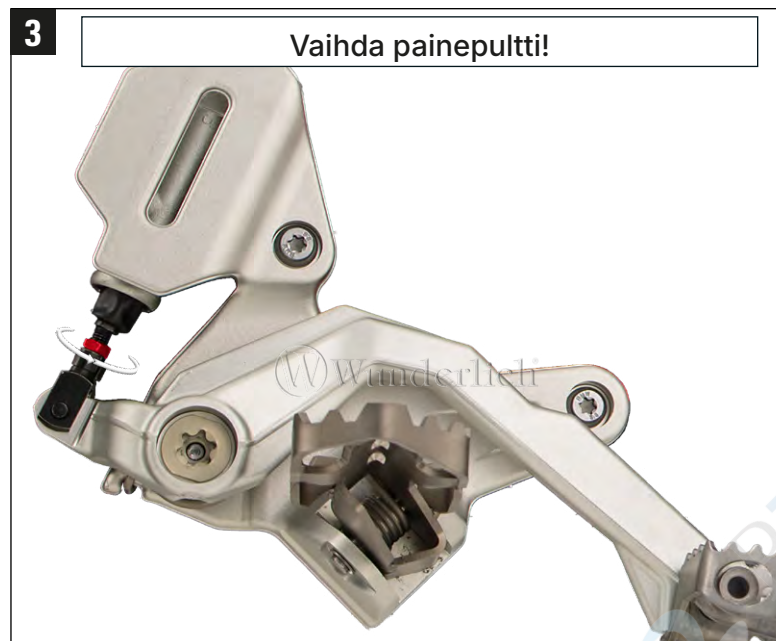
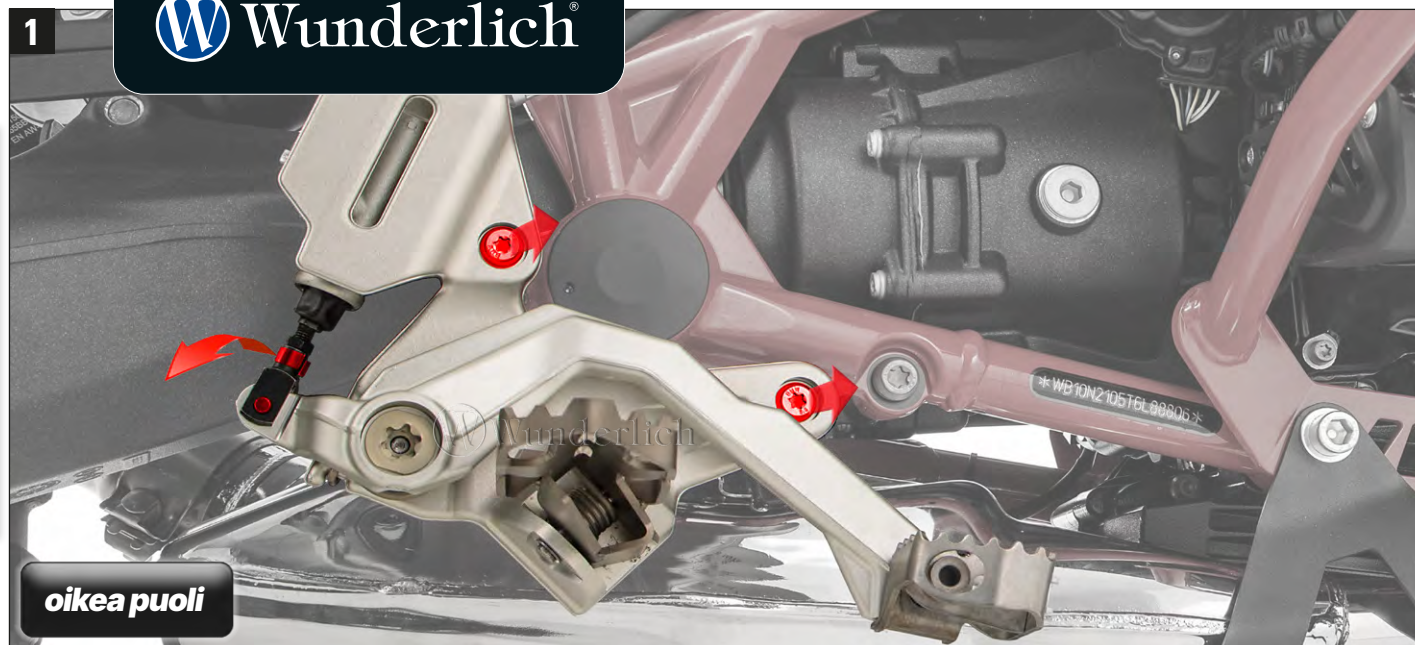

! Asennuksen saa suorittaa vain koulutetut ja asiantuntevat henkilöt tai erikoistyöpajassa.
Asennuksen jälkeen tarkista takapyörän vapaa liike, säädä tarvittaessa painepultti / jarrupoljin (välys 1,3 mm)

5



6

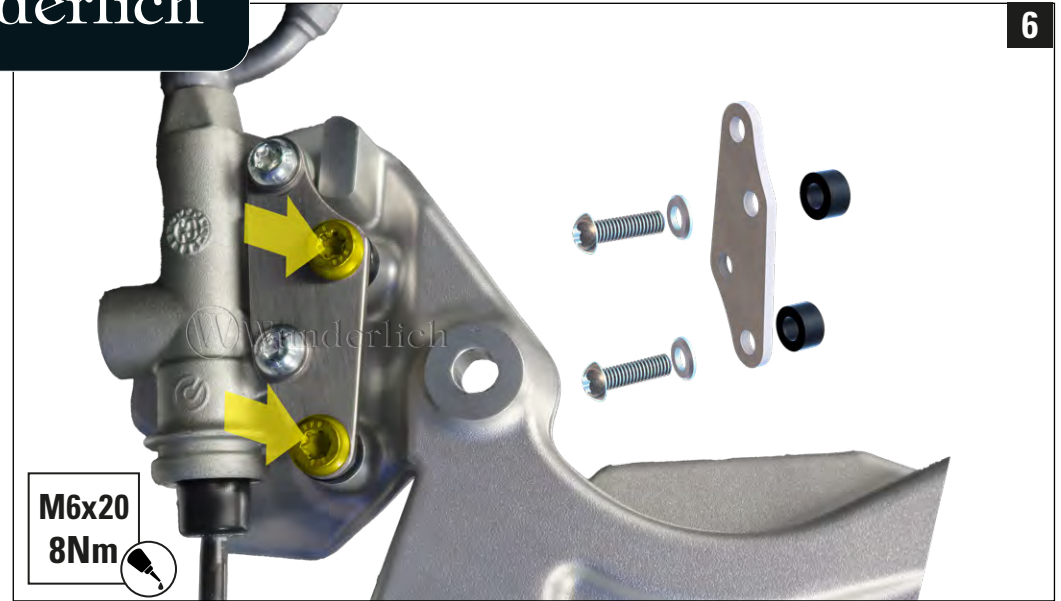

7

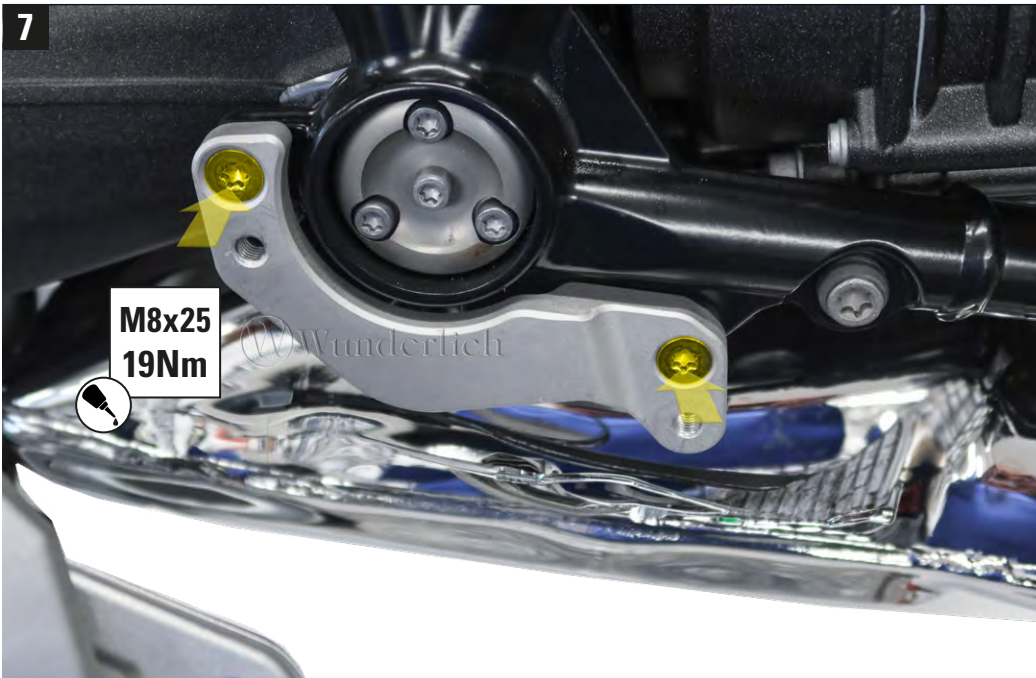

8

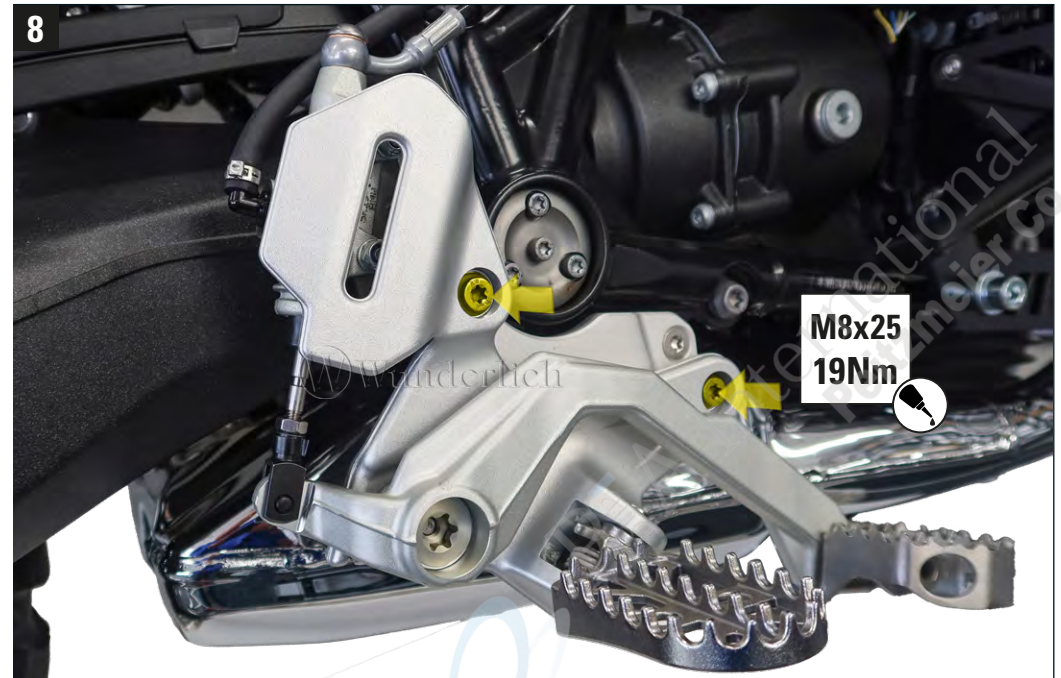

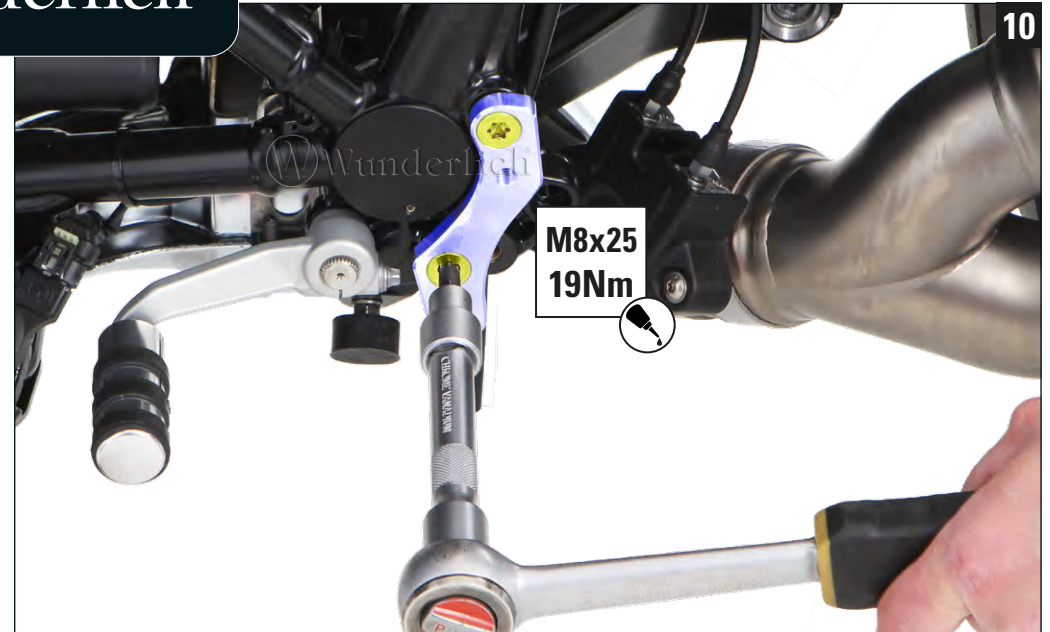

Säädä vaihdepoljin!