





NAVIHALTERUNG

Navigation bracket | Soporte para GPS | Support pour système de navigation | Supporto per navigatore

Art.-Nr: 21176-002 (S1000XR / C400GT)

Art.-Nr: 21178-002 (F900XR)

LEGENDE / Key / file Légende

-  **Anbau Tipp**
Fitting tip
Astuce de montage
-  **Achtung**
Attention
Attention
-  **Vergrößerung**
Magnification
Grossissement
-  **Montagepaste**
Fitting lubricant
Lubrifiant de montage

-  **Schraube**
Screw
Vis
-  **Schraubensicherung**
Thread locking fluid
Freinfilets
-  **Drehmoment**
Torque
Torque
-  **Reiniger**
Cleaner
Nettoyant



#	BEZEICHNUNG / DESCRIPTION	DE EN FR	Die Farben der Abbildungen dienen nur der Veranschaulichung. The colors are for illustrating purposes only. Les couleurs utilisées sont à titre indicatif seulement.			DIN	ISO	MENGE QUANTITY
1	Navihalterung / navigation bracket						1	
2	Linseflanschschraube / lens head screw		M6x55	8Nm	7381SA2	7381SA2	2	
3	Abdeckblech / cover plate (F900XR)						1	

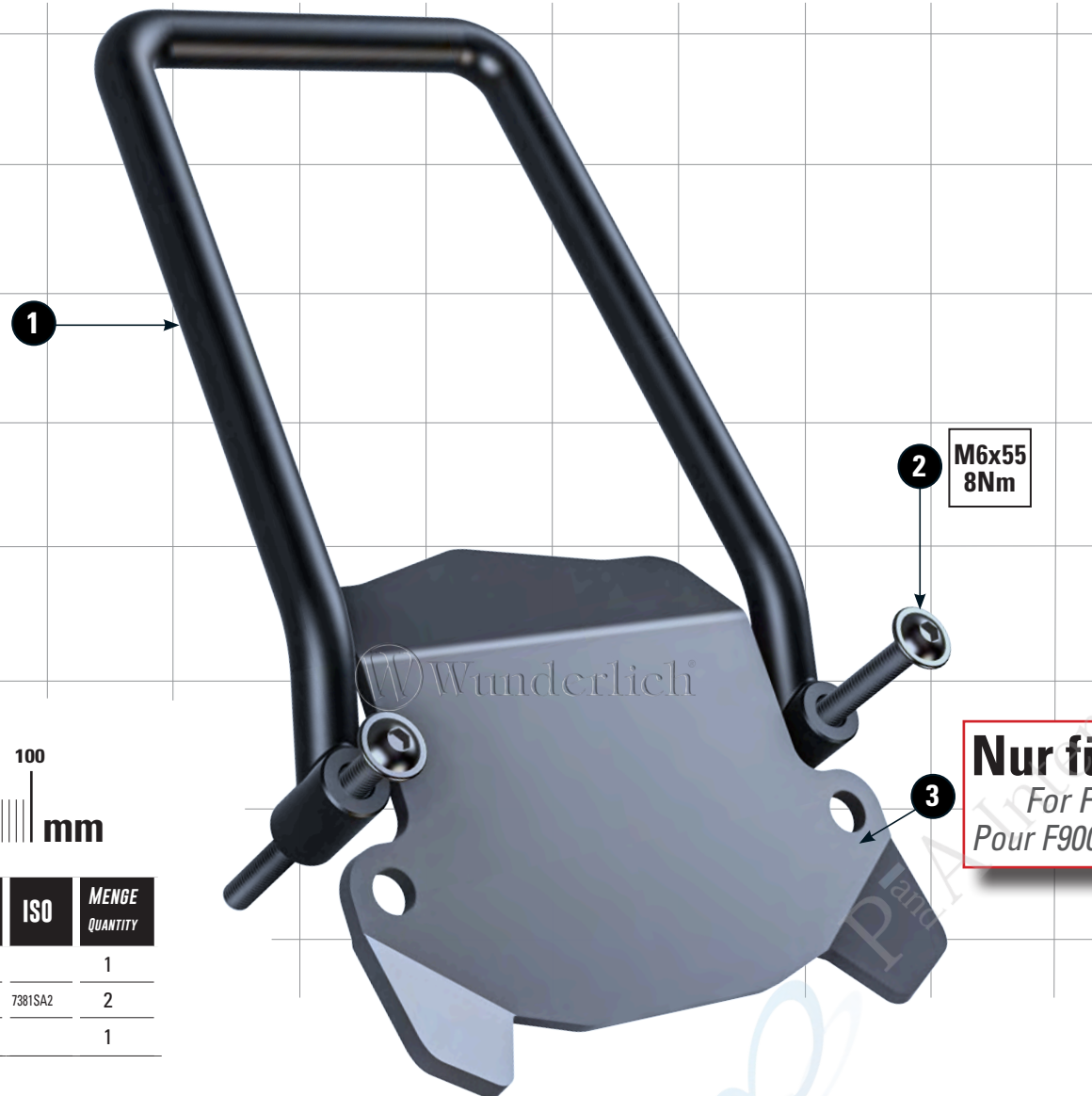

Nur für F900XR
For F900XR only
Pour F900XR uniquement

15.07.2025



S1000XR

Art.-Nr: 21176-002



F900XR

Art.-Nr: 21178-002

Die Demontage/Montage der Verkleidungsscheibe wie bei der S1000XR.

The disassembly/assembly of the windshield is like on the S1000XR.

Le démontage / montage du pare-brise est comme sur le S1000XR.

Die originale Abdeckung (Bild1) entfällt.

The original cover (pic1) is omitted.

La couverture d'origine (image1) est omise.



C400GT

Art.-Nr: 21176-002

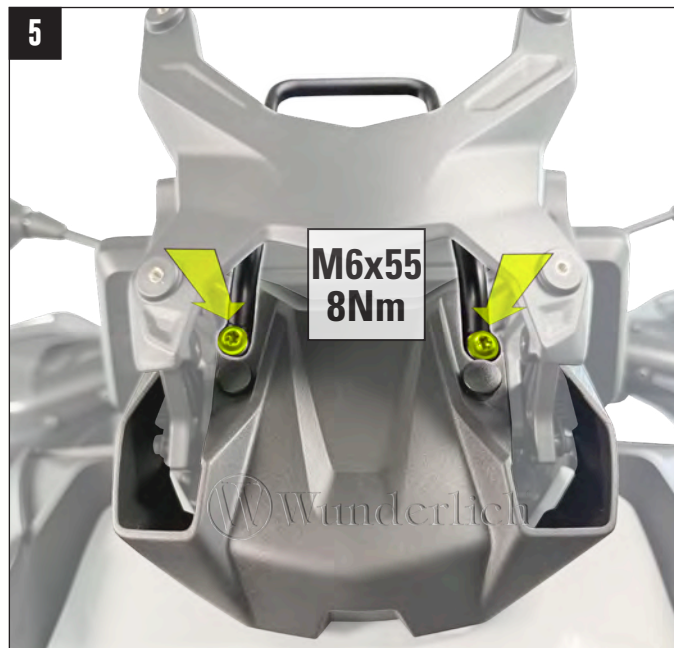
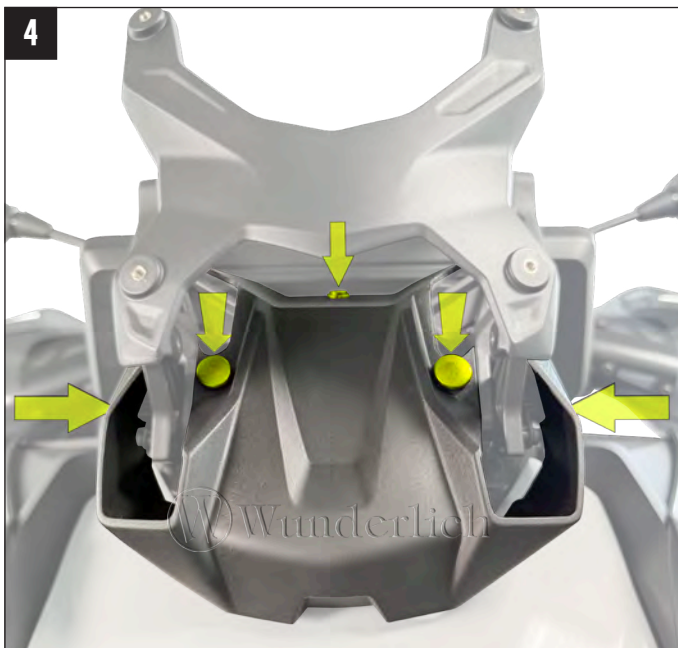
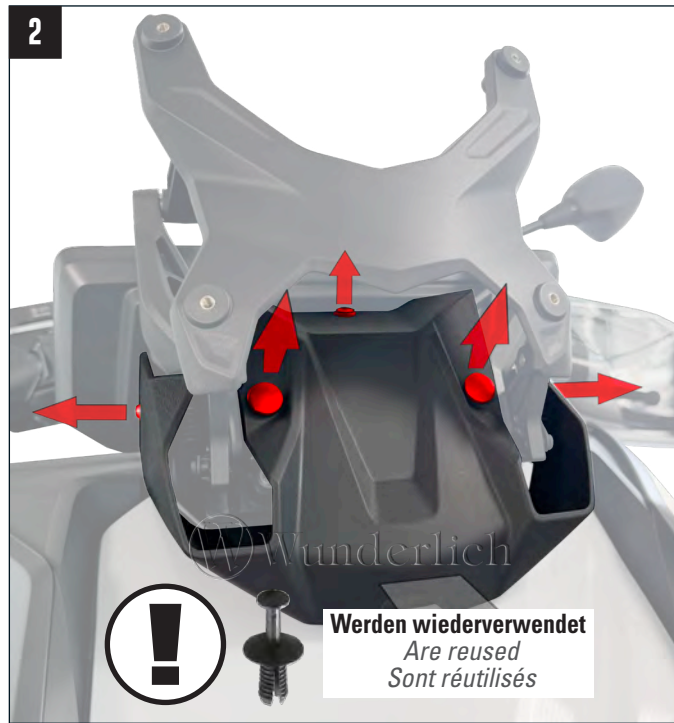
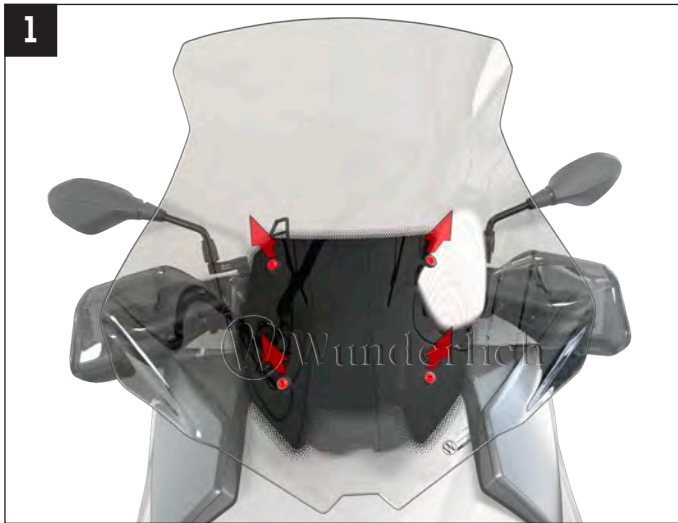

Bearbeiten der originalen Abdeckung (C400GT)

Modifying the original cover (C400GT)

Modification du cache d'origine (C400GT)

Die beiliegende Schablone wie dargestellt ausschneiden.
Cut out the enclosed template as shown.
Découpez le gabarit fourni comme indiqué.

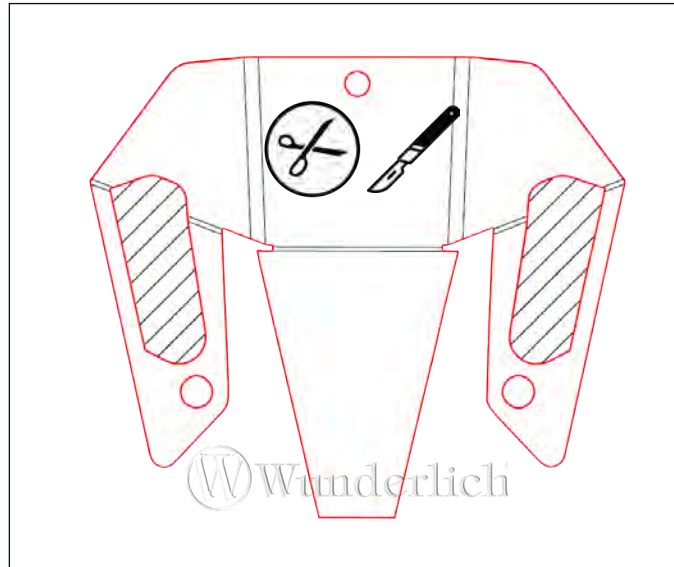

Die ausgeschnittene Schablone wie dargestellt auf die Verkleidung legen und mit den originalen Stopfen fixieren.
Place the cut-out template onto the fairing as shown and secure it using the original plugs.
Placer le gabarit découpé sur le carénage comme indiqué et le fixer avec les bouchons d'origine.

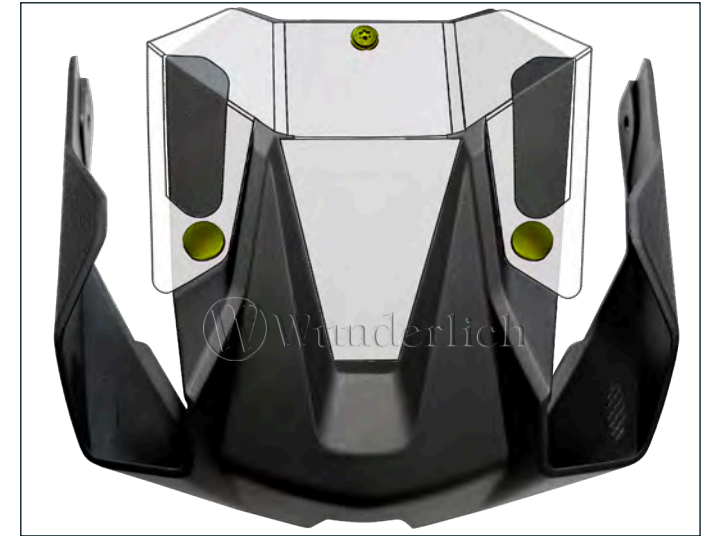

Die dargestellten Bereiche anzeichnen.
Outline the areas shown.
Tracer les zones indiquées.

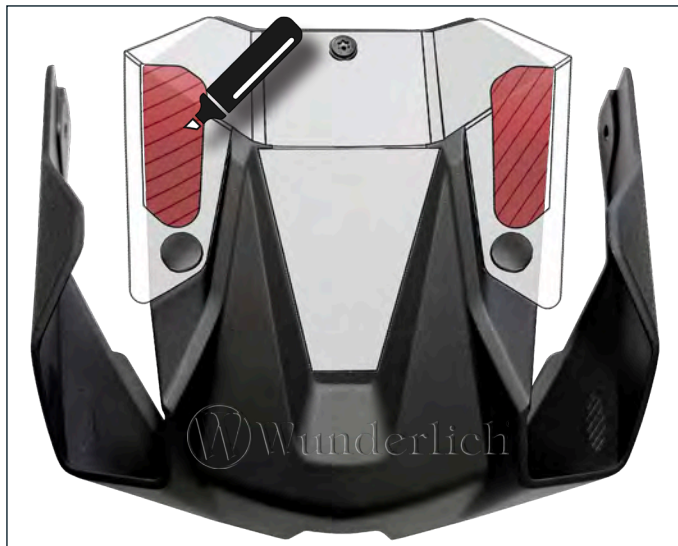

Die angezeichneten Bereiche ausschneiden/ausfräsen.
Cut out/mill the marked areas.
Découper/fraiser les zones marquées.



SCHABLONE C400GT



Achten Sie beim Ausdrucken der Anbauanleitung unbedingt auf die eingestellte Größe des Dokumentes. Es muss die tatsächliche Größe ausgedruckt werden, damit die Schablone das richtige Maß hat. Ob die richtige Größe eingestellt war, können Sie mit einem Lineal an der 100 mm Skala überprüfen.

Please make sure to check the document size setting when printing the installation instructions. The actual size must be printed so that the template has the correct dimensions. You can verify that the correct size was set by measuring the 100 mm scale with a ruler.

Veillez vous assurer de vérifier les paramètres de taille du document lors de l'impression des instructions de montage. L'impression doit être effectuée à l'échelle réelle afin que le gabarit ait les bonnes dimensions. Vous pouvez vérifier que la taille est correcte en mesurant l'échelle de 100 mm avec une règle.

