

MOTORSCHUTZBÜGEL/ ENGINE GUARD



KAWASAKI KLE 500 / SE

(2026-)

Art.Nr./Item-no.:

5012558 00 01 schwarz/black

Inhalt

1x 700015106 Motorschutzbügel links
1x 700015107 Motorschutzbügel rechts
1x 700015108 Schraubensatz:

1	Zylinderschraube M10x1,25x130
1	Zylinderschraube M10x1,25x120
1	Zylinderschraube M10x1,25x90
1	Zylinderschraube M10x1,25x75
2	Zylinderschraube M8x20
4	U- Scheibe Ø10,5
2	U- Scheibe Ø8,4
1	Aludistanz Ø25xØ11x87
1	Aludistanz Ø25xØ11x75
1	Aludistanz Ø25xØ11x44
1	Aludistanz Ø25xØ11x30

Content

1x 700015106 Engine guard left
1x 700015107 Engine guard right
1x 700015108 Screw kit:

1	Allen screw M10x1,25x130
1	Allen screw M10x1,25x120
1	Allen screw M10x1,25x90
1	Allen screw M10x1,25x75
2	Allen screw M8x20
4	Washer Ø10,5
2	Washer Ø8,4
1	Alu spacer Ø25xØ11x87
1	Alu spacer Ø25xØ11x75
1	Alu spacer Ø25xØ11x44
1	Alu spacer Ø25xØ11x30

Hinweis/Notice:

In Kombination mit H&B Tankschutzbügel 5022558 00 01, H&B Motorschutzplatte 8102558 00 01 und originaler großer Motorschutzplatte montierbar.
Can be fitted in combination with the H&B tank guard 5022558 00 01, the H&B skid plate 8102558 00 01 and the original large skid plate.

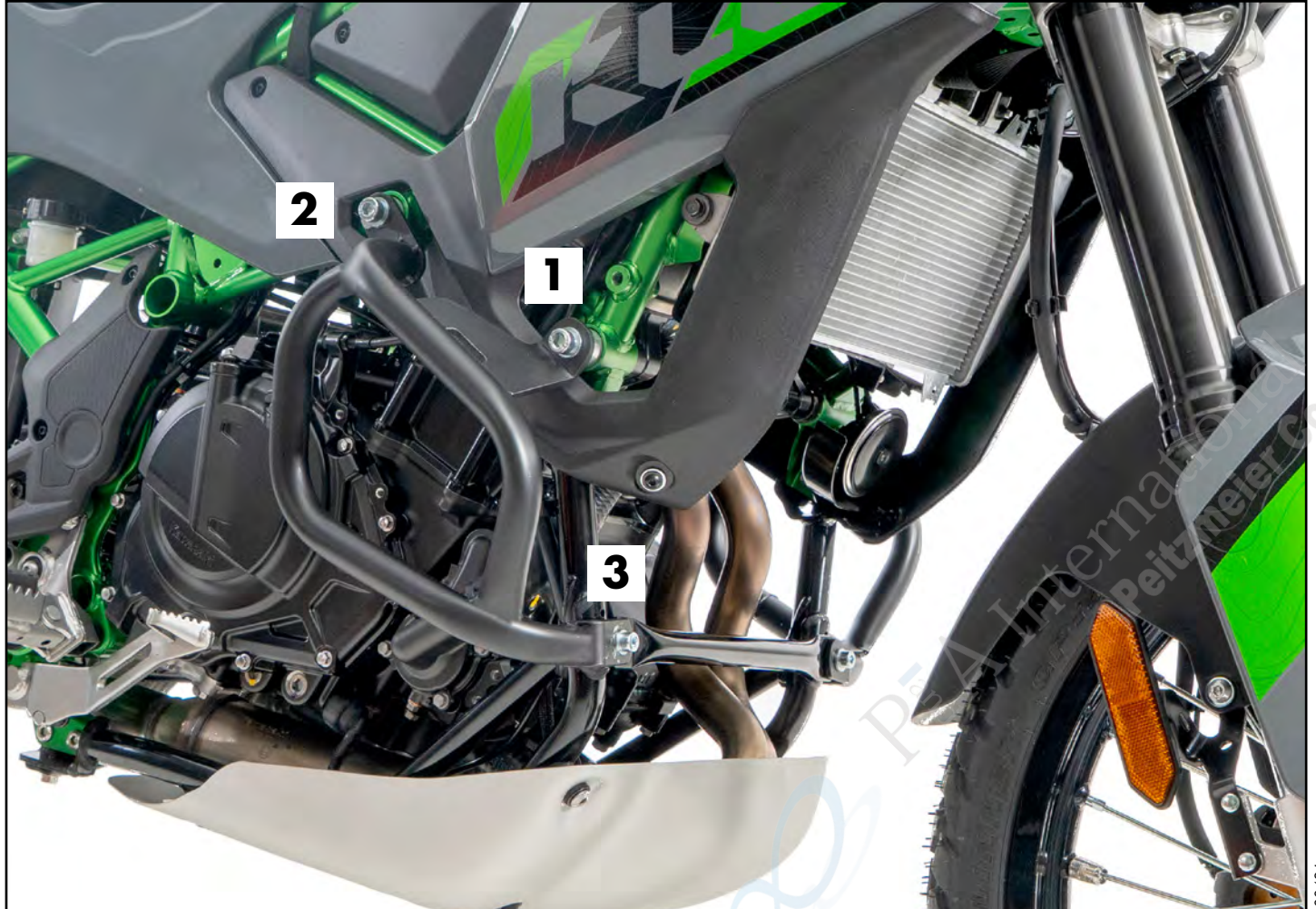

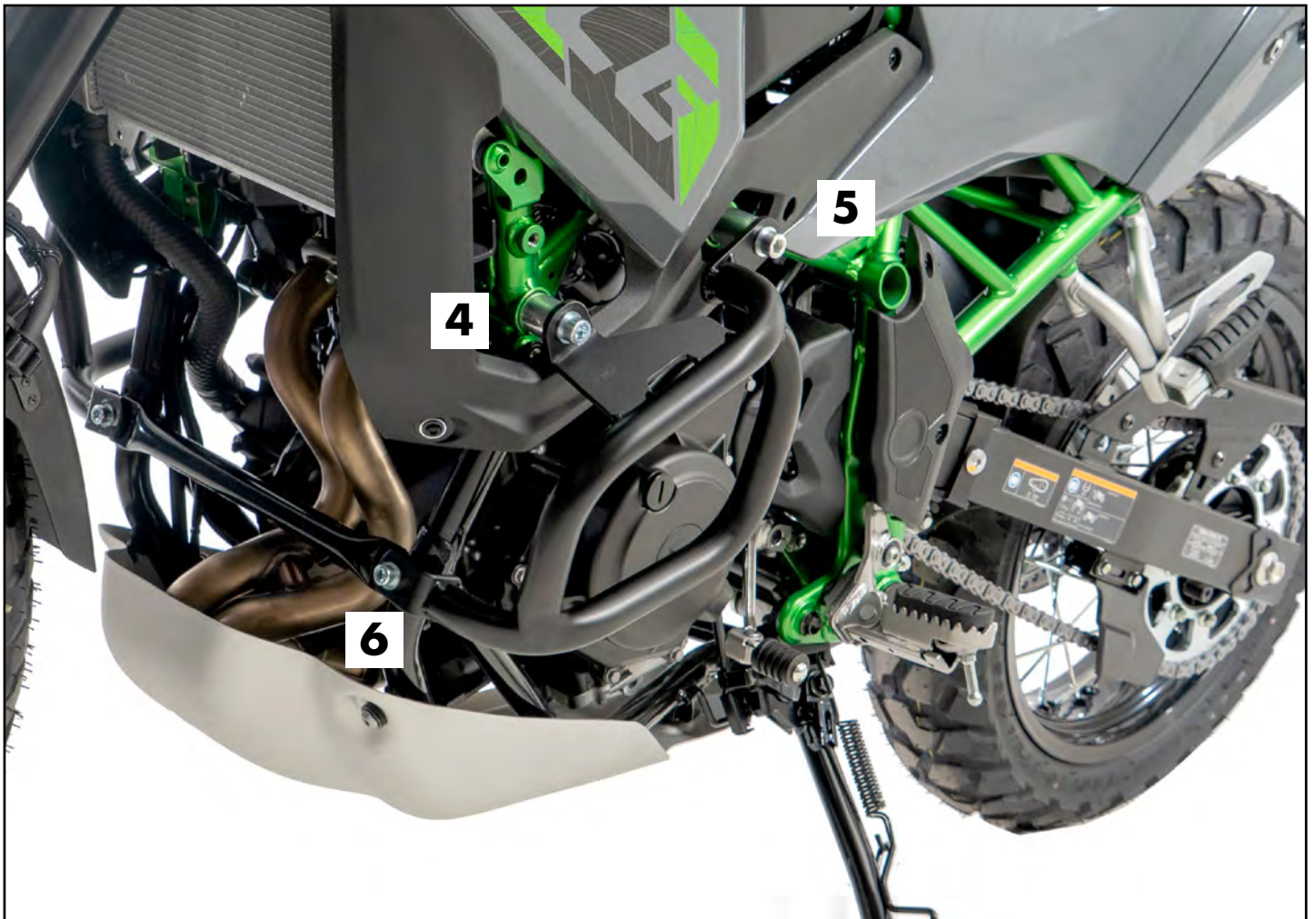

Wichtig / Important:

Beachten Sie die in Ihrem Land geltenden Zulassungsbestimmungen.
Für den Bereich der BRD gilt: Ein Eintrag in die Fahrzeugpapiere ist nicht erforderlich.

Wir empfehlen, die Montage in einer Fachwerkstatt durchführen zu lassen. Bei der Montage, alle zugänglichen Schrauben vorerst nur locker andrehen, sodass eine spannungsfreie Montage gewährleistet wird. Beim Anziehen der Schrauben, Anzugsmomente beachten.

We recommend having the installation carried out in a professional workshop. During installation, tighten all accessible screws loosely at first to ensure tension-free installation. When tightening the screws, observe the tightening torques.

Eine Seite nach der anderen montieren. Ansonsten besteht die Gefahr, dass sich der Motor absenkt.
Mount one side after the other. Otherwise, there is the risk that the engine block change position.

Vorbereitende Maßnahmen / Preparatory actions

Jeweils die obere und vordere Rahmenschraube sowie die Schraube der vorderen Querstrebe entfernen, alle Schrauben entfallen.

Remove the top and front frame bolts as well as the bolt on the front cross-brace; all screws are obsolete.

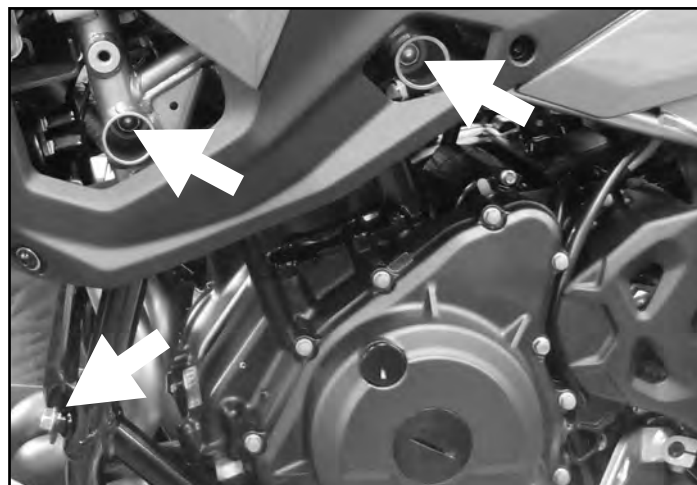

Benötigte Werkzeuge / Required tools

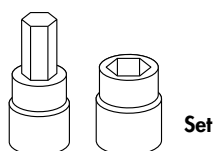

Set

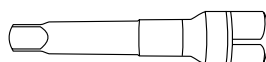

Verlängerung/extension

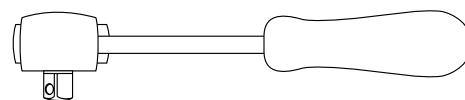

Ratsche/Ratchet

Montageanleitung / Installation instruction

Motorschutzbügel rechts mitte:
Engine guard right middle:

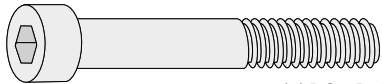
1x  M10x1,25x90

1x  Ø10,5

1x  Ø25xØ11x44

1

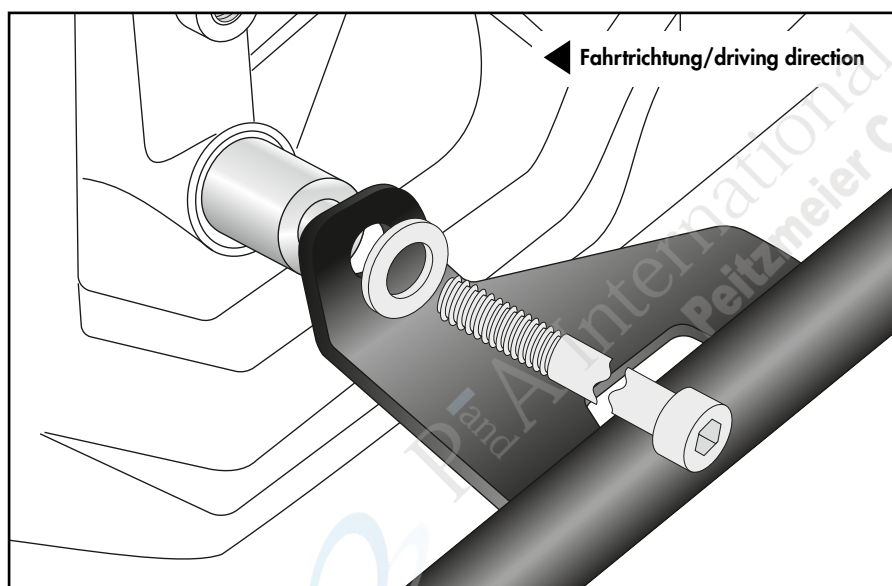

Montageanleitung / Installation Instruction

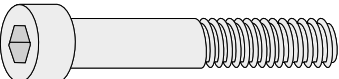
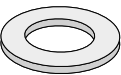
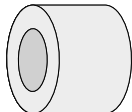

Motorschutzbügel rechts oben: Engine guard right top:

- 1x**  M10x1,25x75
- 1x**  Ø10,5
- 1x**  Ø25xØ11x30

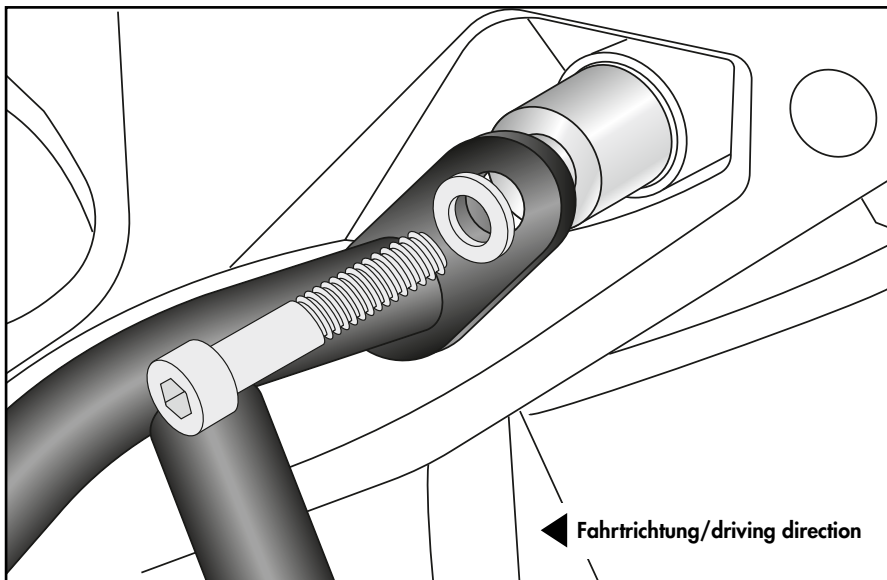
2

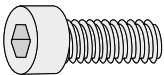

Motorschutzbügel rechts unten: Engine guard right bottom:

- 1x**  M8x20
- 1x**  Ø8,4

3

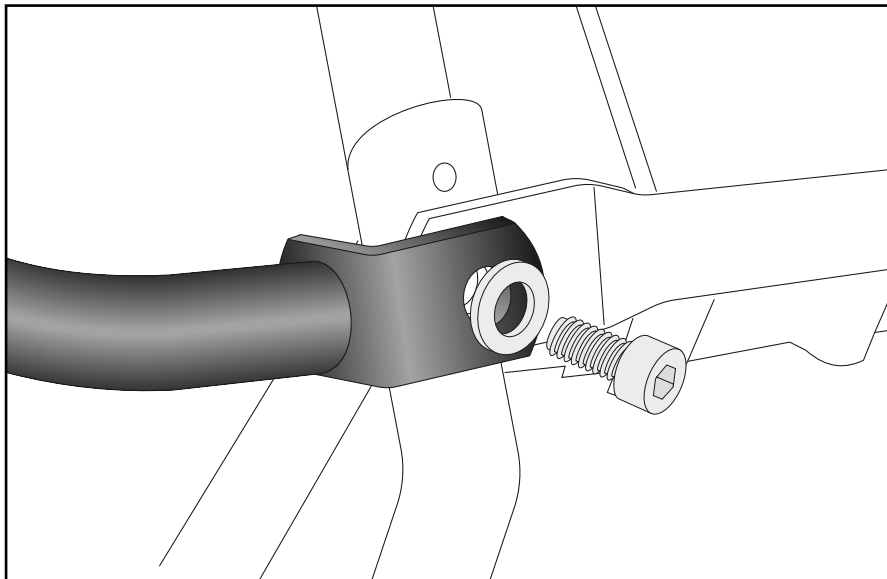

Motorschutzbügel links mitte: Engine guard left middle:

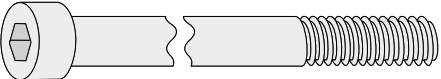
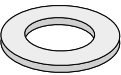
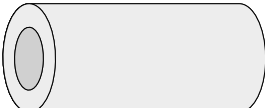

- 1x**  M10x1,25x130
- 1x**  Ø10,5
- 1x**  Ø25xØ11x87

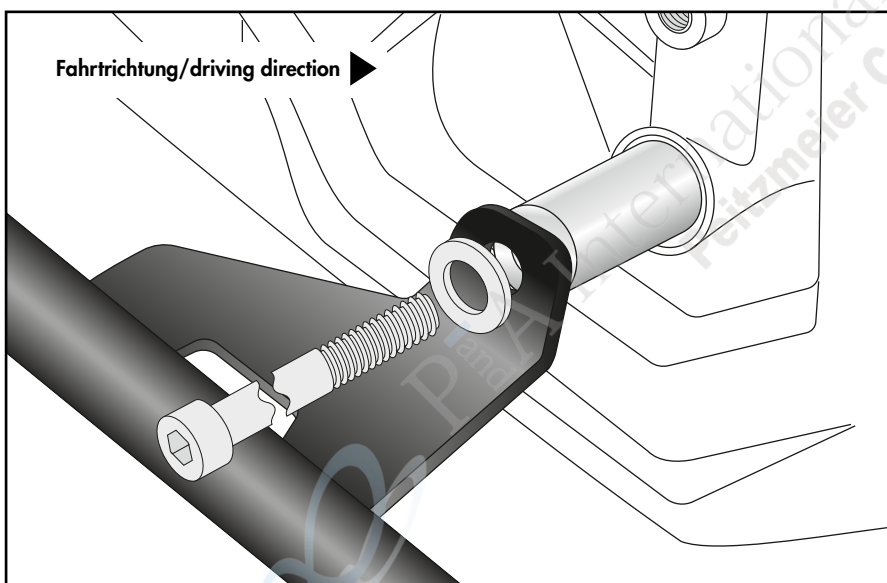
4

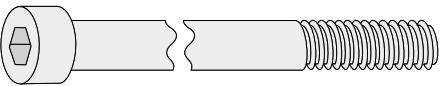
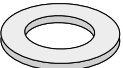

Montageanleitung / Installation Instruction

Motorschutzbügel links oben: Engine guard left top:

- 1x**  M10x1,25x120
- 1x**  Ø10,5
- 1x**  Ø25xØ11x75

Darauf achten, dass die Originaldistanz zwischen Rahmen und Motor verbleibt.
Ensure that the original distance between the frame and the motor is maintained.

5

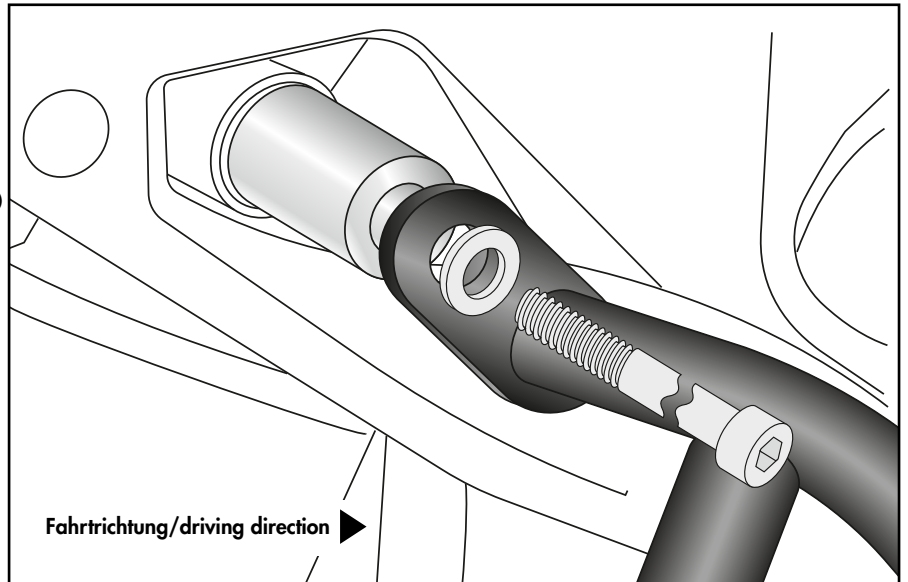

Motorschutzbügel links unten: Engine guard left bottom:

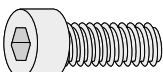
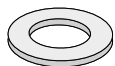
- 1x**  M8x20
- 1x**  Ø8,4

6

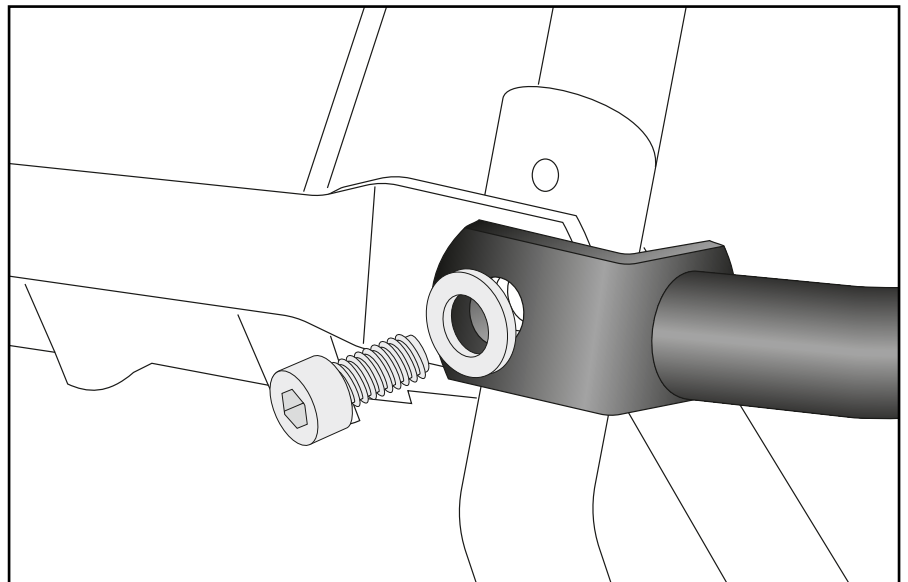

Achtung / Attention:

Nach der Montage alle Verschraubungen auf festen Sitz kontrollieren! Abgebaute Teile wieder montieren. Bitte beachten Sie unsere beigefügten Serviceinformationen.

Control all screw connections after the assembling for tightness! Reassemble the dismantled parts. Please notice our enclosed service information.

Weiteres Zubehör für dieses Modell auf www.hepco-becker.de / More accessories for this model see www.hepco-becker.de

HEPCO&BECKER GmbH | An der Steinmauer 6 | 66955 Pirmasens | Germany | Tel. +49 6331 1453100 | Fax: +49 6331 1453 120 | Mail: vertrieb@hepco-becker.de