



## PROGUARD SYSTEM®

An exclusive RIZOMA patent, the Proguard System is a guard for the brake and clutch levers. Originally conceived for racing, it is also available in a road version, and mounts to a wide range of makes and models.

This type of guard is a response to the extreme sensitivity of the latest high power braking systems - braking performance is better than ever before, but the risk of accident in case of unintentional operation is higher than ever.

 DESIGN REGISTRATION # 1073712  
PATENT PENDING

DESIGN REGISTRATION # 1073712



The PROGUARD SYSTEM® is the world champion with the Gresini Racing Team in the Moto2 category; we are proud to include the testimonial of the winning rider, who uses Proguard on his motorcycle:

"Proguard is an extremely useful technical accessory, one which I think is indispensable for Moto2, a category in which close contacts with other bikes are frequent and where it is easy to get your brake or clutch lever hooked onto your adversary's bike, which can result in very dangerous falls.

Proguard completely eliminates this risk, which makes it very useful in racing. It's also very good looking and easy to customize with your number or name decals. I put my number, 24, on my Proguard - and it seems to have brought me luck!"

Tony Elias



The PROGUARD SYSTEM® is the ideal solution for:

### SAFETY

During motorcycle races, many accidents occur when the brake lever is actuated in contact with another motorcycle, which can lead to dangerous falls for the rider. Even on the road, in the midst of traffic, contact with other vehicles can operate the brake lever - especially with car rearview mirrors.

The Proguard System protects the end of the levers, thus significantly reducing the potential for contact with other vehicles and thus the risk of accidents.

### AERODYNAMICS

Numerous track and wind tunnel tests have shown that at over 180 kph, brake and clutch levers are subject to wind force capable of generating a pressure of 0.7-0.8 bar in the hydraulic circuit. This unintentional, continuous actuation wears the brake pads and causes the clutch disk to slip, thus overheating the systems as well as reducing their efficiency.

The PROGUARD SYSTEM®, as can be seen from the images taken from wind tunnel tests, cancels out this wind force, thus ensuring optimal operation of the hydraulic systems.

### STYLE

Compared with conventional commercial guards, the PROGUARD SYSTEM® stands out not only for its technical characteristics but also for its exceptional styling.

The challenge has been to reduce the aesthetic disturbance to a minimum while maintaining the functional characteristics, to create an accessory which makes the motorcycle not only safer to ride, but even more aggressive and forceful looking.

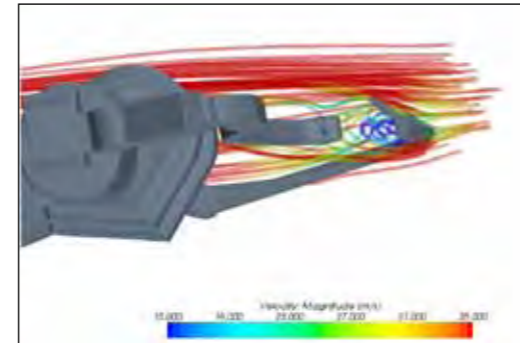

## PROGUARD SYSTEM®

POSITION	□	■	■
RIGHT	LP011A	LP011B	LP011G
LEFT	LP012A	LP012B	LP012G

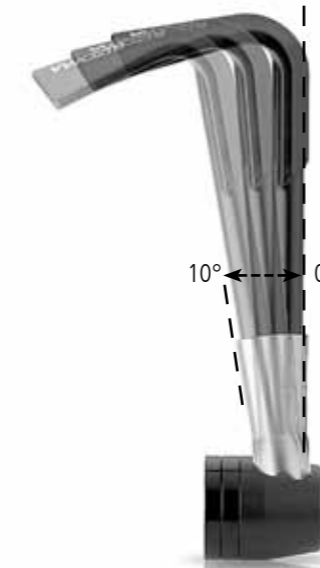

### ADAPTERS FOR HANDLEBARS Ø 13-20 mm

D (mm)	CODE
13-21	LP200B

### ADAPTERS FOR ORIGINAL HANDLEBARS

BRAND		CODE	EACH
APRILIA®	RSV4	LP200B	
BMW®	K1300R	LP320B	
BMW®	S1000RR	LP321B	
BMW®	F800R	LP322B	
BUELL®	ALL	LP200B	
DUCATI®	ALL	LP200B	
HONDA®	ALL	LP200B	
KAWASAKI®	Z750R	LP200B	
KAWASAKI®	ALL	LP305B	
KTM®	ALL	LP200B	
MV AGUSTA®	BRUTALE 1090	LP200B	
SUZUKI®	ALL	LP200B	
TRIUMPH®	STREET TRIPLE 675	LP310B	
TRIUMPH®	STREET TRIPLE R675	LP310B	
TRIUMPH®	ALL OTHER MODELS	LP200B	
YAMAHA®	YZF R1	INCLUDED	
YAMAHA®	YZF R6 06 -	INCLUDED	
YAMAHA®	YZF R6 99 - 05	LP200B	
YAMAHA®	ALL OTHER MODELS	LP300B	

### TECHNICAL INFO

the kit includes:  
01 screw M6x40  
UNI5931

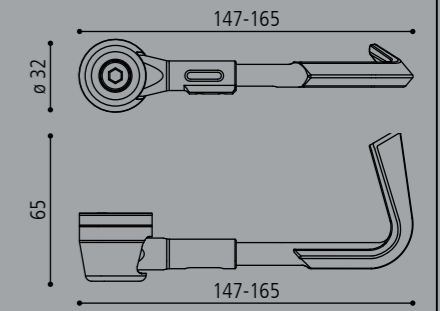

### TECHNICAL INFO

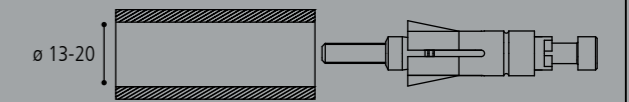

### TECHNICAL INFO

